

SHERWOOD VALVE COMPRESSED GAS PRODUCTS





A History of Quality and Innovation

For nearly a century, Sherwood has been the world's leading provider of system-critical compressed gas solutions serving blue-chip bulk and specialty gas manufacturers, distributors and storage & delivery system providers (OEMs).

Sherwood had its beginnings in Buffalo, NY in 1923. Over the last 90 years, we have earned a reputation for products that not only keep pace with customer requirements, but also anticipate their changing needs. Our expert engineering and product development teams continuously work to improve Sherwood's core competencies and create new, innovative products to meet the industry's ever-changing standards and demands.

Today Sherwood Valve has three manufacturing facilities near Pittsburgh, PA and Cleveland, OH.

Manufacturing Quality, Safety and Reliability

Automated manufacturing processes throughout Sherwood's operations are set up to eliminate 97% of all touch labor, resulting in consistently higher-quality products. We've added many new advanced process controls, including infrared thermal imaging to ensure optimization at every stage in the manufacturing process, and helium leak checking for quality, safety and reliability.

We're using the latest technology available to lower costs and increase quality. For example, Sherwood's Industrial Automation Center produces up to 6500 assembled and tested valves per shift. And to help ensure quality for our customers, this equipment features automated self-diagnostic and maintenance procedures that increase manufacturing efficiency and output.

Sherwood is a totally integrated brass valve manufacturer. We manufacture our own rod and raw forgings at our foundry. These forgings are then machined into the bodies that we use in our valves. Because we manufacture our own brass rod, we can control the alloy components more closely, resulting in a more durable forging.

All Sherwood products are designed to meet the highest standards, and only quality materials are used. For example, Sherwood's specialty gas products for medical and breathing apparatuses are cleaned and assembled in a strictly controlled, clean environment. Careful assembly and detailed inspection of every part ensure top performance and durability. Sherwood is fully certified to the stringent requirements of ISO 9001, which increase manufacturing efficiency and reliability.

Your Valve Partner

Sherwood's diverse product lines of specialty gas, compressed gas, refrigeration products, propane and life-support equipment have enabled us to develop varied and diverse technical expertise. Our engineering team includes experts in product design and development as well as experts in the quality and compliance testing requirements needed to create custom valves to meet your unique applications.

Sherwood is partnered with a solid network of worldwide industry leaders, distributors, manufacturing representatives and customers supporting continuous improvement. Sherwood is your partner for the best quality valves, delivered on time, at the best possible price!



Contents	Page
Industrial Gas Valves	
GV & GVHM Series, <i>Global Industrial Gas Valves</i>	2-6
GRPV Series, <i>Residual Pressure Valves</i>	7-11
MVHM Series, <i>Monel Valves</i>	12-13
SVHM Series, <i>Stainless Steel</i>	14-15
BV Series, <i>Hi/Lo Valves with Built-In Regulators</i>	16-18
1206A Series, <i>Ammonia Packed Wrench-Operated Valves</i>	19-20
Acetylene Valves	
AV Series, <i>Small Cylinder Acetylene Valves</i>	21-24
GV Acetylene Series, <i>Large Cylinder Acetylene Valves</i>	25
GVT Series, <i>Vertical Outlet Acetylene Valves</i>	26
Medical Valves	
KVAB Series, <i>Post Medical Valves</i>	27-29
KVMB Series, <i>Post Medical Valves for MRI Environments</i>	30
GV-MRI Series, <i>Global Valves for MRI Environments</i>	31
OxyGen I Series, <i>Oxygen Valves with Integrated Pressure Regulators</i>	32-34
YVBA Series, <i>Vertical Outlet Oxygen Valves</i>	35-37
Propane Cylinder Valves	
DOT Propane Cylinder Valves.....	38-39
DOT Propane Forklift Valves.....	40-44
Alternative Energy Valves	
NGV, NGVHM & NGRPV Series, <i>Global Industrial Gas Valves for Hydrocarbon-Based Flammable Gases</i>	45-47
NBV Series, <i>CNG Ball Valves</i>	48
PVE3250 Series, <i>Propylene Valves</i>	49-50
DF Series, <i>Alternative Fuel Valves</i>	51-52
Specialty Applications	
YVA Series, <i>High-Pressure Line Valves</i>	53-54
430 Series, <i>Master Shut-Off Valves</i>	55-56
Refrigerant Recovery Series, <i>Refrigerant Recovery Valves</i>	57-58
Refrigerant Recovery Series, <i>Refrigerant Cylinder Valves</i>	59-60
Fuse Plugs and Pressure Relief Devices	
Fuse Plugs.....	61
Pressure Relief Devices.....	62
Pressure Relief Devices Technical Information.....	63-64
Pressure Relief Device Numbering Matrix: Unitized Plug Series.....	65
Product Markings	
Product Markings Reference.....	66
KVAB and KVMB Date Code Tables.....	67-68
Appendix	
DOs and DO NOTs for Valve Use.....	69
Valve Part Numbering Matrix: Global Valves.....	70
Valve Part Numbering Matrix: DF Series.....	71
Cylinder Valve Selection.....	72-80
Sherwood Valve, LLC Limited Warranty.....	81

GV & GVHM Series

Global Industrial Gas Valves

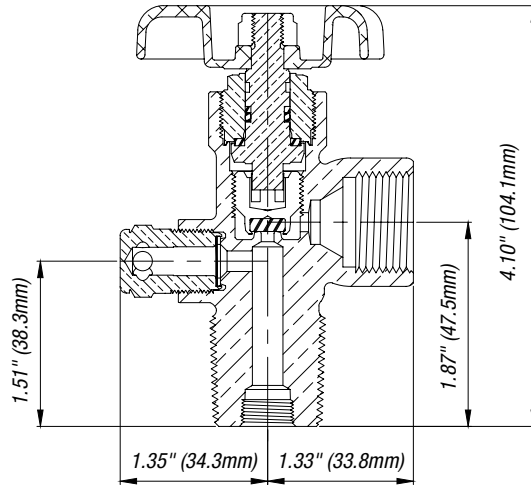

GV Series
Up to 3000 PSI Working Pressure

Designed for use in every country around the world. For use in cylinders containing oxygen, argon, carbon dioxide, nitrogen, helium and hydrogen, as well as welding gas mixtures.

Key Features & Benefits

- Automated assembly and testing processes ensure exceptional quality
- 100% helium leak tested
- Heavy-duty forged brass body for durability and high pressure
- Precisely machined internal components meet the most stringent international valve performance standards
- Pressure Relief Device (PRD) is a unitized plug design that provides excellent flow characteristics, ensures proper assembly and tamper resistance
- Metal-to-metal seal below bonnet threads prevents pressure in the threads at top of valve body
- Direct-drive stem design with optimized O-ring (GV) or double O-ring (GVHM) seal reduces friction and operates at exceptionally low torque levels
- Inlet and outlet thread configurations are available for a broad spectrum of customer, country and code specifications
- Tapped for dip tube as required

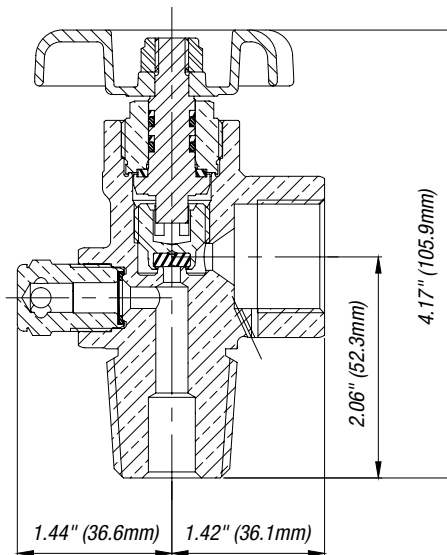

GVHM Series
3000 PSI and Above Working Pressure

For Product Markings Reference, see **A** on page 66.

GV & GVHM Series

Global Industrial Gas Valves

Design Specifications		
	English	Metric
Maximum Working Pressure	GV: 3500 PSI GVHM: 6000 PSI	GV: 241 Bar GVHM: 413 Bar
Burst Pressure	GV: 10,000 PSI GVHM: 13,500 PSI	GV: 689 Bar GVHM: 931 Bar
Operating Temperature Range	-50° F → +149° F	-45° C → +65° C
Storage Temperature Range	-65° F → +155° F	-54° C → +68° C
Leak Rate Internal/External	GV: 1x10 ⁻³ atm cc/sec. GVHM: 1x10 ⁻⁴ atm cc/sec.	GV: 1x10 ⁻³ Bar mL/sec. GVHM: 1x10 ⁻⁴ Bar mL/sec.
Minimum Cycle Life	2000 Cycles	
Cv Flow Factor	Standard: .690 CO ₂ /Manifold: 1.23	
Closing Torque	20–30 in.-lbs.	2.2–3.3 N-m
Operating Torque	10–20 in.-lbs.	1.1–2.2 N-m
Bonnet Installation Torque	GV: 50–60 ft.-lbs. GVHM: 60–70 ft.-lbs.	GV: 68–81 N-m GVHM: 81–95 N-m
Handwheel Nut Installation Torque	15–35 in.-lbs.	1.7–3.9 N-m
PRD Installation Torque	GV: 25–35 ft.-lbs. GVHM: 40–50 ft.-lbs.	GV: 34–47 N-m GVHM: 54–68 N-m
PRD Flow Capacity	60 cfm @ 100 PSI	1700 L/min. @ 6.9 Bar

Materials of Construction		
Sherwood Part Number	Part Description	Materials of Construction
<i>GV & GVHM Series Industrial and Chrome-Plated Valves</i>		
N/A	Body	Forged Brass C37700; Chrome Plating When Applicable
N/A	Bonnet	Brass C36000; Chrome Plating When Applicable
1919A	Handwheel	Aluminum A380
1251-6	Handwheel Nut	Steel Class 8, Zinc Plating
N/A	Lower Plug	Brass C48500
N/A	Lower Plug Seat	Nylon Zytel 101
See Chart on Page 62	PRD	Plug: Brass C36000; Chrome Plating When Applicable Rupture Disc: Nickel Alloy 201; Copper C22000 Webbed Seal Gasket: Copper Dead Soft C11000
N/A	Stem	Brass C36000
G011EP	O-Ring	Ethylene Propylene (EPDM)
N/A	Back-up O-Ring	Ethylene Propylene (EPDM)
N/A	Thrust Washer	Delrin® 500 AF

Standards Conformance	
CGA V-9	Standard for Gas Cylinder Valves
CGA S1.1	Standard for Pressure Relief Devices
CGA V-1	Compressed Gas Cylinder Valve Outlet and Inlet Specifications
ISO 10297	International Standard for Cylinder Valves Design Specifications
ISO 11363-1	25E Inlet Thread Specifications
AS2473	Australian Standard for Compressed Gas Cylinder Valves
A-A-59860	U.S. General Services Administration Standards for Gas Cylinder Valves

Inlet O-Ring for Straight Threaded GV Valves		
Sherwood Part Number	Size	Material
G907A	.625 UNF	Buna-N
G210A-9	.750 UNF	Buna-N
G216B	1.125 UNF	Buna-N
G016T	.625 UNF	PTFE
G210T	.750 UNF	PTFE
P1100X15-20T	1.125 UNF	PTFE

Lubricants	
Christo-Lube	Used in Valves for All Industrial Gas Applications
Turmoxygen	Used in GVHM Valves for Oxygen Service

NOTE: GV & GVHM Series valves are not for use with CNG applications. For CNG Service, see NGV and NGVHM Series on pages 45-47. No mechanical addition of force is to be used with handwheel-style valves without the use of controlled torque.

Industrial Gas Valves

GV & GVHM Series

Global Industrial Gas Valves

For further ordering information, refer to the Selection of Pressure Relief Devices on page 62, the Pressure Relief Device Numbering Matrix on page 65, the Product Markings Reference on page 66 and the Valve Part Numbering Matrix on page 70.

Ordering Information				
Sherwood Part Number	Gas Service @ 70° F	CGA Outlet	Outlet Thread Size	Inlet Thread Size
<i>Carbon Dioxide</i>				
GV32041-XX	0 PSI–3000 PSI	320	.825–14 NGO RH Ext.	½"–14 NGT
GV32061-XX	0 PSI–3000 PSI	320	.825–14 NGO RH Ext.	¾"–14 NGT
GV32081-XX	0 PSI–3000 PSI	320	.825–14 NGO RH Ext.	1"–11½ NGT
GV32025E1-XX	0 PSI–3000 PSI	320	.825–14 NGO RH Ext.	25E ISO
GV32051-XX-75	0 PSI–3000 PSI	320	.825–14 NGO RH Ext.	.750–16 UNF
GV32051-XX	0 PSI–3000 PSI	320	.825–14 NGO RH Ext.	1.125–12 UNF
<i>Nitrous Oxide</i>				
GV32641-XX	0 PSI–3000 PSI	326	.825–14 NGO RH Ext.	½"–14 NGT
GV32661-XX	0 PSI–3000 PSI	326	.825–14 NGO RH Ext.	¾"–14 NGT
GV32681-XX	0 PSI–3000 PSI	326	.825–14 NGO RH Ext.	1"–11½ NGT
GV32625E1-XX	0 PSI–3000 PSI	326	.825–14 NGO RH Ext.	25E ISO
GV32651-XX-75	0 PSI–3000 PSI	326	.825–14 NGO RH Ext.	.750–16 UNF
GV32651-XX	0 PSI–3000 PSI	326	.825–14 NGO RH Ext.	1.125–12 UNF
<i>Air</i>				
GV34641-XX	0 PSI–3000 PSI	346	.825–14 NGO RH Ext.	½"–14 NGT
GV34661-XX	0 PSI–3000 PSI	346	.825–14 NGO RH Ext.	¾"–14 NGT
GV34681-XX	0 PSI–3000 PSI	346	.825–14 NGO RH Ext.	1"–11½ NGT
GV34625E1-XX	0 PSI–3000 PSI	346	.825–14 NGO RH Ext.	25E ISO
GV34651-XX-75	0 PSI–3000 PSI	346	.825–14 NGO RH Ext.	.750–16 UNF
GV34651-XX	0 PSI–3000 PSI	346	.825–14 NGO RH Ext.	1.125–12 UNF
GVHM34761-XX	3001 PSI–4700 PSI	347	.825–14 NGO RH Ext.	¾"–14 NGT
GVHM70261-XX	4701 PSI–6400 PSI	702	1.125–14 NGO RH Int.	¾"–14 NGT
<i>Carbon Monoxide and Hydrogen</i>				
GV35045-XX	0 PSI–3000 PSI	350	.825–14 NGO LH Ext.	½"–14 NGT
GV35065-XX	0 PSI–3000 PSI	350	.825–14 NGO LH Ext.	¾"–14 NGT
GV35085-XX	0 PSI–3000 PSI	350	.825–14 NGO LH Ext.	1"–11½ NGT
GV35025E5-XX	0 PSI–3000 PSI	350	.825–14 NGO LH Ext.	25E ISO
GV35055-XX-75	0 PSI–3000 PSI	350	.825–14 NGO LH Ext.	.750–16 UNF
GV35055-XX	0 PSI–3000 PSI	350	.825–14 NGO LH Ext.	1.125–12 UNF
GVHM69565-XX	3001 PSI–4700 PSI	695	1.045–14 NGO LH Int.	¾"–14 NGT
GVHM70365-XX	4701 PSI–6400 PSI	703	1.125–14 NGO LH Int.	¾"–14 NGT
<i>Oxygen</i>				
GV54041-XX	0 PSI–3000 PSI	540	.903–14 NGO RH Ext.	½"–14 NGT
GV54061-XX	0 PSI–3000 PSI	540	.903–14 NGO RH Ext.	¾"–14 NGT
GV54081-XX	0 PSI–3000 PSI	540	.903–14 NGO RH Ext.	1"–11½ NGT
GV54051-XX-75	0 PSI–3000 PSI	540	.903–14 NGO RH Ext.	.750–16 UNF
GV54051-XX	0 PSI–3000 PSI	540	.903–14 NGO RH Ext.	1.125–12 UNF
GVHM57761-XX	3001 PSI–3500 PSI	577	.960–14 NGO RH Ext.	¾"–14 NGT
GVHM70161-XX	3501 PSI–4700 PSI	701	1.103–14 NGO RH Ext.	¾"–14 NGT
<i>Argon, Helium, Krypton, Neon, Nitrogen and Xenon</i>				
GV58041-XX	0 PSI–3000 PSI	580	.965–14 NGO RH Int.	½"–14 NGT
GV58061-XX	0 PSI–3000 PSI	580	.965–14 NGO RH Int.	¾"–14 NGT
GV58081-XX	0 PSI–3000 PSI	580	.965–14 NGO RH Int.	1"–11½ NGT
GV58025E1-XX	0 PSI–3000 PSI	580	.965–14 NGO RH Int.	25E ISO
GV58051-XX-75	0 PSI–3000 PSI	580	.965–14 NGO RH Int.	.750–16 UNF
GV58051-XX	0 PSI–3000 PSI	580	.965–14 NGO RH Int.	1.125–12 UNF
GVHM68061-XX	3001 PSI–4700 PSI	680	1.045–14 NGO RH Int.	¾"–14 NGT
GVHM67761-XX	4701 PSI–6400 PSI	677	1.030–14 NGO LH Ext.	¾"–14 NGT
<i>Sulfur Hexafluoride</i>				
GV59041-XX	0 PSI–3000 PSI	590	.965–14 NGO LH Int.	½"–14 NGT
GV59061-XX	0 PSI–3000 PSI	590	.965–14 NGO LH Int.	¾"–14 NGT
GV59081-XX	0 PSI–3000 PSI	590	.965–14 NGO LH Int.	1"–11½ NGT
GV59025E1-XX	0 PSI–3000 PSI	590	.965–14 NGO LH Int.	25E ISO
GV59051-XX-75	0 PSI–3000 PSI	590	.965–14 NGO LH Int.	.750–16 UNF
GV59051-XX	0 PSI–3000 PSI	590	.965–14 NGO LH Int.	1.125–12 UNF

NOTE: For GV and GVHM Series options, see following page.

Parts Breakdown for GV or GVHM Series Industrial and Chrome-Plated Valves

- A. Handwheel Nut** **1251-6**
- B. Handwheel** **1919A**
- C. Bonnet and Stem Assembly Includes:** **1400-30-XXX (GV)**
1400-32GVH-XXX (GVHM)**
 Bonnet, Back-Up O-Ring*, O-Ring*, Thrust Washer, Stem
- D. Lower Plug and Seat Assembly Includes:** **1400-40 (Standard)**
1400-40A (CO₂ /Manifold)
 Lower Plug and Seat
- E. Pressure Relief Device Unitized Assembly Includes:** **P625-19X9-XX (GV)**
P625-19X9H-XX (GVHM)
 Plug, Rupture Disc and Webbed Seal Washer

* GVHM has two O-rings.
 ** For XXX options, see kits below.

For further ordering information, refer to the Selection of Pressure Relief Devices on **page 62**, the Pressure Relief Device Numbering Matrix on **page 65**, the Product Markings Reference on **page 66** and the Valve Part Numbering Matrix on **page 70**.

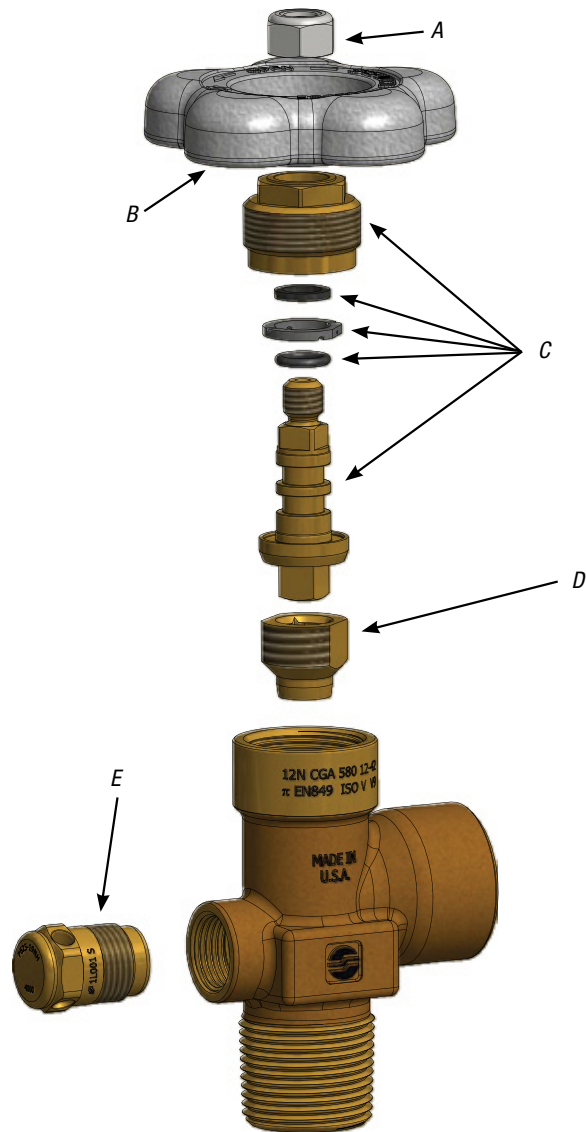

GV Key Replacement Parts	
Sherwood Part Number	Description
<i>GV Kits, Brass</i>	
1400-30-101KIT	Each kit includes 25 Bonnet and Stem Assemblies, Christo-Lube
<i>GV Kits, Plated</i>	
1-1400-30-101KIT	Each kit includes 25 Bonnet and Stem Assemblies, Christo-Lube

GVHM Key Replacement Parts	
Sherwood Part Number	Description
<i>GVHM Kits, Brass</i>	
1400-32GVH-100KIT	Each kit includes 25 Bonnet and Stem Assemblies, Turmoxygen
1400-32-GVH-101KIT	Each kit includes 25 Bonnet and Stem Assemblies, Christo-Lube
<i>GVHM Kits, Plated</i>	
1-1400-32GVH-100KIT	Each kit includes 25 Bonnet and Stem Assemblies, Turmoxygen
1-1400-32-GVH-101KIT	Each kit includes 25 Bonnet and Stem Assemblies, Christo-Lube

Ordering Options (Refer to Ordering Information on previous page for base part numbers.)

Oversize Inlets: 4 and 7 (low-pressure) and 24 (high-pressure only) threads oversize inlets: To order, add -4, -7 or -24 to the end of the Part Number. For example, GV34661-XX becomes GV34661-XX-7.

Chrome plating: To order, add letter "A" after letters GV or GVHM in the Part Number. For example, GV34661-XX becomes GVA34661-XX.

Lexan® polycarbonate handwheels: To order, add suffix LX to the end of the Part Number. For example, GV34661-XX becomes GV34661-XXLX.

Fusible backed Pressure Relief Devices in 165° F or 212° F nominal melting temperatures:

NOTE: For CNG service valves, see NGV & NGVHM Series on pages 45–47.



GV Series Cylinders

For Manifold, Oxygen and Fuel Gas



GV58060

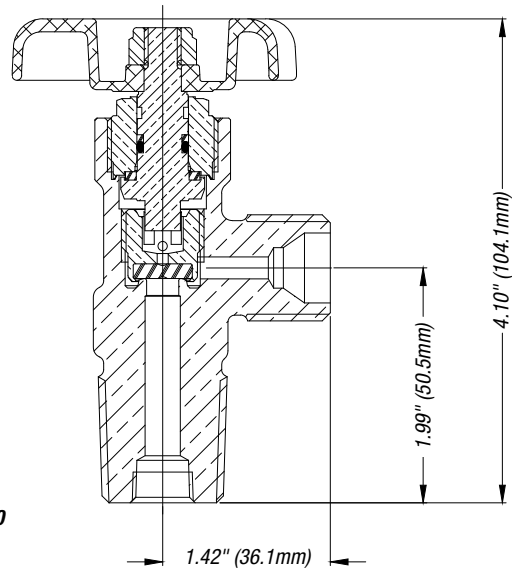

For further ordering information, refer to the Product Markings Reference on page 66 and the Valve Part Numbering Matrix on page 70.

Ordering Information				
Sherwood Part Number	CGA Outlet	Outlet Thread Size	Inlet Thread Size	Description
<i>GV O-Ring-Style Manifold Valves</i>				
GV32040	320	.825"-14 NGO	1/2"-NGT	No PRD
GV32060	320	.825"-14 NGO	3/4"-NGT	No PRD
GV35040	350	.825"-14 NGO	1/2"-NGT	No PRD
GV35060	350	.825"-14 NGO	3/4"-NGT	No PRD
GV54040	540	.903"-14 NGO	1/2"-NGT	No PRD
GV54060	540	.903"-14 NGO	3/4"-NGT	No PRD
GV58040	580	.965"-14 NGO	1/2"-NGT	No PRD
GV58060	580	.965"-14 NGO	3/4"-NGT	No PRD
GVHM68060	680	1.045"-14 NGO	3/4"-NGT	No PRD
<i>GV O-Ring-Style Cylinder Valves, Tapered Thread for Fuel Gas and Oxygen</i>				
GV02240	022	.5625"-18 UNF	1/2"-NGT	No PRD
GV02240CC	022	.5625"-18 UNF	1/2"-NGT	No PRD; Cap and Chain
GV02340	023	.5625"-18 UNF	1/2"-NGT	No PRD
GV02340CC	023	.5625"-18 UNF	1/2"-NGT	No PRD; Cap and Chain
GV02440	024	.875"-14 UNF	1/2"-NGT	No PRD
GV02440CC	024	.875"-14 UNF	1/2"-NGT	No PRD; Cap and Chain
GV02540	025	.875"-14 UNF	1/2"-NGT	No PRD
GV02540CC	025	.875"-14 UNF	1/2"-NGT	No PRD; Cap and Chain

For Product Markings Reference, see **A** on page 66.

GRPV Series

Residual Pressure Valves

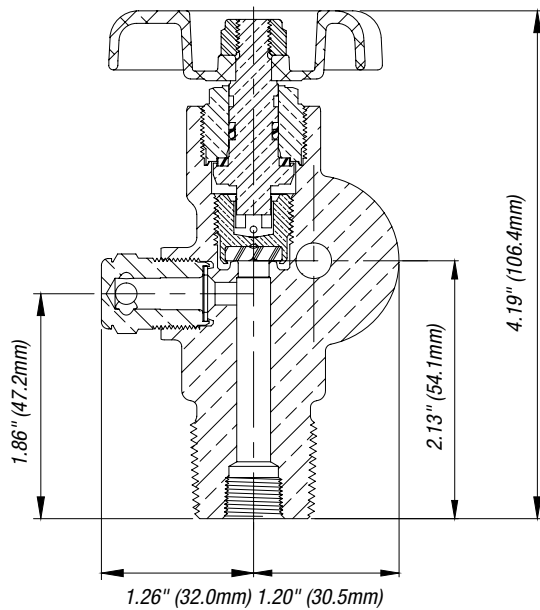

GRP V

Residual pressure valve designed to protect cylinder and contents.

Key Features & Benefits

- Prevents backflow of impurities and foreign substances
- Automated assembly and testing processes ensure exceptional quality
- 100% helium leak tested
- Durable forged brass body, precisely machined internal components and design elements meet the most stringent international valve performance standards
- Innovative design and quality construction offer protection of cylinder contents without the expense of a time-consuming purge-and-clean cycle
- Retains approximately 30 to 50 PSI pressure, maintaining the integrity of the cylinder contents against contaminants, even if the valve is left open
- Protects and extends life of cylinder by preventing ingress of moisture
- Pressure Relief Device (PRD) unitized plug design provides excellent flow characteristics
- Dynamic front piston seal design is not in direct contact with the flow passage during filling
- Inlet and outlet thread configurations are available for a broad spectrum of customer, country and code specifications
- Optical Character Recognition technology utilized to verify appropriate burst disc pressure rating
- Exclusive “webbed washer” design protects burst disc during handling and bulk shipment
- Maximizes optimum fill flow rate and provides high flow for delivery of product with Cv factor of .43

For Product Markings Reference, see **B** on page 66.

Industrial Gas Valves

GRPV Series

Residual Pressure Valves

For further ordering information, refer to the Selection of Pressure Relief Devices on **page 62**, the Pressure Relief Device Numbering Matrix on **page 65**, the Product Markings Reference on **page 66** and the Valve Part Numbering Matrix on **page 70**.

Design Specifications		
	English	Metric
Maximum Working Pressure	3500 PSI	413 Bar
Burst Pressure	10,000 PSI	1035 Bar
Operating Temperature Range	-50° F → +149° F	-45° C → +65° C
Storage Temperature Range	-65° F → +155° F	-54° C → +68° C
Leak Rate Internal/External	1x10 ⁻³ atm cc/sec.	1x10 ⁻³ Bar mL/sec.
Minimum Cycle Life	2000 Cycles	
Cv Flow Factor	Standard: .28 CO ₂ /Manifold: .50	
Closing Torque	20–30 in.-lbs.	2.2–3.3 N-m
Operating Torque	10–20 in.-lbs.	1.1–2.2 N-m
Bonnet Installation Torque	50–60 ft.-lbs.	68–81 N-m
Handwheel Nut Installation Torque	15–35 in.-lbs.	1.7–3.9 N-m
PRD Installation Torque	25–35 ft.-lbs.	34–47 N-m
PRD Flow Capacity	60 cfm @ 100 PSI	1700 L/min. @ 6.9 Bar

Materials of Construction		
Sherwood Part Number	Part Description	Materials of Construction
N/A	Body	Brass C37700/Chrome Plating When Applicable
N/A	Bonnet	Brass C36000/Chrome Plating When Applicable
1919A	Handwheel	Aluminum A380
1251-6	Handwheel Nut	Steel Class 8, Zinc Plating
N/A	Lower Plug	Brass C48500
N/A	Lower Plug Seat	Nylon Zytel 101
See Chart on Page 62	PRD	Plug: Brass C36000/Chrome Plating When Applicable Rupture Disc: Nickel Alloy 201; Copper C22000 Webbed Seal Gasket: Copper Dead Soft C11000
N/A	Stem	Brass C36000
G011EP	O-Ring	Ethylene Propylene (EPDM)
N/A	Back-up O-Ring	Ethylene Propylene (EPDM)
N/A	Thrust Washer	Delrin® 500 AF
N/A	RPV Piston	Brass C37700
N/A	RPV Plug	Brass C36000/Chrome Plating When Applicable
N/A	RPV Spring	Beryllium Copper
N/A	Piston O-Ring	Ethylene Propylene (EPDM)
N/A	Piston O-Ring	Ethylene Propylene (EPDM)
N/A	RPV Plug O-Ring	Ethylene Propylene (EPDM)

Standards Conformance	
CGA V-9	Standard for Gas Cylinder Valves
CGA S1.1	Standard for Pressure Relief Devices
CGA V-1	Compressed Gas Cylinder Valve Outlet and Inlet Specifications
ISO 10297	International Standard for Cylinder Valves Design Specifications
ISO 11363-1	25E Inlet Thread Specifications
ISO 15996	International Standard for Residual Pressure Valves Design Specifications
AS2473	Australian Standard for Compressed Gas Cylinder Valves
A-A-59860	U.S. General Services Administration Standards for Gas Cylinder Valves

Inlet O-Ring for Straight Threaded GRPV Series Residual Pressure Valves		
Sherwood Part Number	Size	Material
G216A	1.125 UNF	Buna-N

Lubricants	
Christo-Lube	Used in Valves for All Industrial Gas Applications
Turmoxygen	Used in Valves for Oxygen Service

GRPV Series

Residual Pressure Valves

For further ordering information, refer to the Selection of Pressure Relief Devices on [page 62](#), the Pressure Relief Device Numbering Matrix on [page 65](#), the Product Markings Reference on [page 66](#) and the Valve Part Numbering Matrix on [page 70](#).

Ordering Information				
Sherwood Part Number	Gas Service @ 70° F	CGA Outlet	Outlet Thread Size	Inlet Thread Size
<i>Air</i>				
GRPV34641-XX	0 PSI–3000 PSI	346	.825–14 NGO RH Ext.	½"–14 NGT
GRPV34661-XX	0 PSI–3000 PSI	346	.825–14 NGO RH Ext.	¾"–14 NGT
GRPV34625E1-XX	0 PSI–3000 PSI	346	.825–14 NGO RH Ext.	25E
GRPV34761-XX	0 PSI–3000 PSI	347	.825–14 NGO RH Ext.	¾"–14 NGT
GV34725E1-XX	0 PSI–3000 PSI	347	.825–14 NGO RH Ext.	25E
<i>Argon</i>				
GRPV58041-XX	0 PSI–3000 PSI	580	.965–14 NGO RH Int.	½"–14 NGT
GRPV58061-XX	0 PSI–3000 PSI	580	.965–14 NGO RH Int.	¾"–14 NGT
GRPV58025E1-XX	0 PSI–3000 PSI	580	.965–14 NGO RH Int.	25E
GRPV68061-XX	3001 PSI–4700 PSI	680	1.045–14 NGO RH Int.	¾"–14 NGT
GRPV68025E1-XX	3001 PSI–4700 PSI	680	1.045–14 NGO RH Int.	25E
<i>Carbon Dioxide</i>				
GRPV32041-XX	0 PSI–3000 PSI	320	.825–14 NGO RH Ext.	½"–14 NGT
GRPV32061-XX	0 PSI–3000 PSI	320	.825–14 NGO RH Ext.	¾"–14 NGT
GRPV32051-XX	0 PSI–3000 PSI	320	.825–14 NGO RH Ext.	1.125"–12 UNF
GRPV32025E1-XX	0 PSI–3000 PSI	320	.825–14 NGO RH Ext.	25E
<i>Helium</i>				
GRPV58041-XX	0 PSI–3000 PSI	580	.965–14 NGO RH Int.	½"–14 NGT
GRPV58061-XX	0 PSI–3000 PSI	580	.965–14 NGO RH Int.	¾"–14 NGT
GRPV58025E1-XX	0 PSI–3000 PSI	580	.965–14 NGO RH Int.	25E
GRPV68061-XX	3001 PSI–4700 PSI	680	1.045–14 NGO RH Int.	¾"–14 NGT
GRPV68025E1-XX	3001 PSI–4700 PSI	680	1.045–14 NGO RH Int.	25E
<i>Hydrogen</i>				
GRPV35045-XX	0 PSI–3000 PSI	350	.825–14 NGO LH Ext.	½"–14 NGT
GRPV35065-XX	0 PSI–3000 PSI	350	.825–14 NGO LH Ext.	¾"–14 NGT
GRPV35025E5-XX	0 PSI–3000 PSI	350	.825–14 NGO LH Ext.	25E
<i>Nitrogen</i>				
GRPV58041-XX	0 PSI–3000 PSI	580	.965–14 NGO RH Int.	½"–14 NGT
GRPV58061-XX	0 PSI–3000 PSI	580	.965–14 NGO RH Int.	¾"–14 NGT
GRPV58025E1-XX	0 PSI–3000 PSI	580	.965–14 NGO RH Int.	25E
GRPV68061-XX	3001 PSI–4700 PSI	680	1.045–14 NGO RH Int.	¾"–14 NGT
GRPV68025E1-XX	3001 PSI–4700 PSI	680	1.045–14 NGO RH Int.	25E
<i>Oxygen</i>				
GRPV54041-XX	0 PSI–3000 PSI	540	.903–14 NGO RH Ext.	½"–14 NGT
GRPV54061-XX	0 PSI–3000 PSI	540	.903–14 NGO RH Ext.	¾"–14 NGT
GRPV54025E1-XX	0 PSI–3000 PSI	540	.903–14 NGO RH Ext.	25E
GRPV57725E1-XX	0 PSI–3500 PSI	577	.903–14 NGO RH Ext.	25E
GRPV57761-XX	0 PSI–3500 PSI	577	.960–14 NGO-RH-Ext.	¾"–14 NGT
<i>Sulfur Hexafluoride</i>				
GRPV59041-XX	0 PSI–3000 PSI	590	.965–14 NGO LH Int.	½"–14 NGT
GRPV59061-XX	0 PSI–3000 PSI	590	.965–14 NGO LH Int.	¾"–14 NGT
GRPV59025E1-XX	0 PSI–3000 PSI	590	.965–14 NGO LH Int.	25E

Options

To order 4, 7 or 24 threads oversize inlets, add -4, -7 or -24 to the end of the Part Number (e.g. GRPV58061-XX becomes GRPV58061-XX-7).

To order chrome plating, add letter "A" after letters GV in the Part Number (e.g. GRPV58061-XX becomes GRPVA58061-XX).

To order fusible backed Pressure Relief devices in 165° F or 212° F nominal melting temperatures, change 1 in the Part Number to 4 (165° F) or to 5 (212° F) (e.g. GRPV35061-XX becomes GRPV35064-XX for 165° F, or GRPV35065-XX for 212° F).

NOTE: GRPV valves are not approved for CNG service. For CNG Service, see NGRPV Series on [pages 45–47](#). Not all valves are available in all configurations. Contact factory for availability. Orders may be subject to minimum quantities.



GRPV Series

Residual Pressure Valves

Parts Breakdown for GRPV Series Residual Pressure Valves

- A. Handwheel Nut** **1251-6**
- B. Handwheel** **1919A**
- C. Bonnet and Stem Assembly Includes:** **1400-30-100** (Oxygen)
1400-30-101 (All Others)
 Bonnet, Back-Up O-Ring, O-Ring, Thrust Washer and Stem
- D. Lower Plug and Seat Assembly** **1400-40** (Standard)
 Includes: Lower Plug and Seat **1400-40A** (CO₂ /Manifold)
- E. Pressure Relief Device Includes: Plug, Rupture Disc and Webbed Seal Washer** **P625-19X-XX**
- F. Includes RPV Assembly, Plug, O-Rings, Spring and Piston** **GRPV-KIT**
- G. Includes O-Rings and Piston Assembly** **GRPV-NVA-KIT**

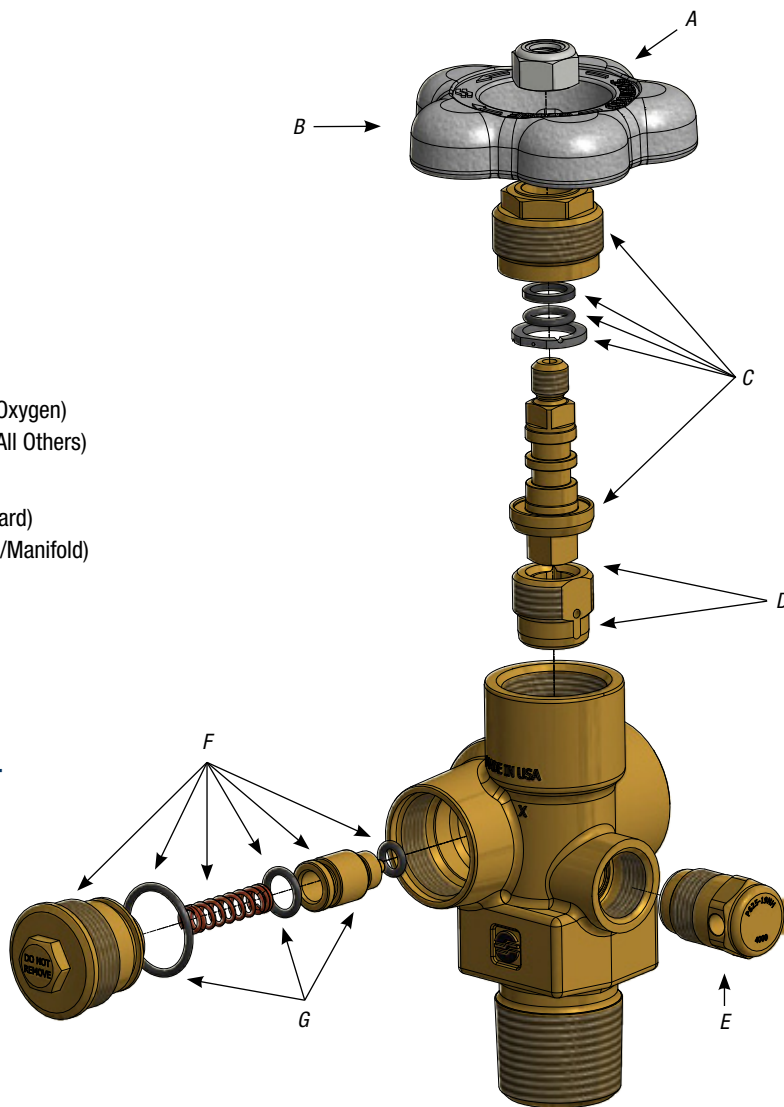

For further ordering information, refer to the Selection of Pressure Relief Devices on **page 62**, the Pressure Relief Device Numbering Matrix on **page 65**, the Product Markings Reference on **page 66** and the Valve Part Numbering Matrix on **page 70**.

GRPV Key Replacement Parts	
Sherwood Part Number	Description
GRPV-KIT	Total RPV Assembly Kit, 50 Each
GRPV-NVA-KIT	Piston Assembly Kit Only, 25 Each

Fill Adapters for GRPV Series

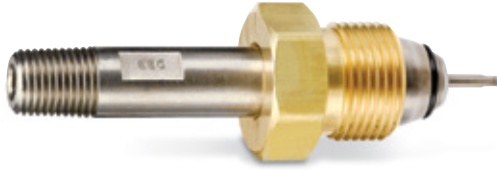

Ordering Information	
Sherwood Part Number	Outlet
<i>Adapters with Retractable Pin</i>	
TLG580SLW*	CGA 580
TLG590SLW*	CGA 590

Retractable Pin Adapters provide maximum operating flexibility to fill or evacuate a cylinder with either a conventional valve or a GRPV. Engage the Pin Locking Tool (see below) and rotate the tool clockwise to depress the pin for use with a conventional valve. Or rotate the tool counterclockwise to release the pin for use with a GRPV valve. The adapters incorporate an O-ring seal for a hand-tight connection.

**Adapters can be used with TV RPV also.*

TLG580, TLG580SLW Rebuild Kit	
Sherwood Part Number	Description
TL580A-30-R	Each kit includes 25 Plunger & Pin Assemblies
TL580	Nose Bushing Torque Spanner sold separately



Ordering Information	
Sherwood Part Number	Description
TL580B	Pin Locking Tool

Used with Retractable Pin Adapter.

Understanding Fill Adapter Part Numbers	
TLG	Tool for Global Valve
L	Retractable Pin
S	Stainless Steel
W	Washer or O-Ring Seal
D	Matching CGA Outlet and Inlet



Ordering Information	
Sherwood Part Number	Outlet
<i>Fixed Pin Adapters, Spring-Loaded, Adjustable</i>	
TLG320W	CGA 320
TLG346S	CGA 346
TLG350S	CGA 350
TLG540S	CGA 540
TLG680S	CGA 680
TL580D*	CGA 580
TL590D*	CGA 590

Fixed Pin Adapters are for use on manifolds dedicated to filling cylinders with Sherwood GRPV valves.

**Adapters can be used with TV RPV also.*



Ordering Information	
Sherwood Part Number	Description
TL580C	Checking Rod

Gas cylinders can be checked for content integrity by simply inserting the Checking Rod and pushing against the resistance of the check valve. The sound of escaping gas indicates residual cylinder pressure.

MVHM Series Monel Valves



MVHM

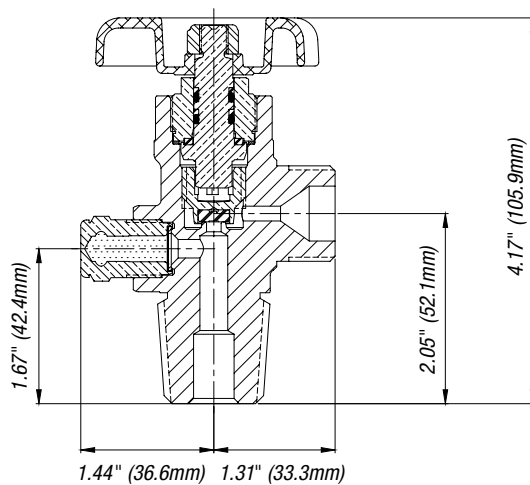

MVHM

Tough forged Monel® construction for extreme corrosive environments.

Key Features & Benefits

- Designed to resist stress corrosion cracking as well as toxic atmospheres
- Corrosion resistant
- Compatible with high-pressure oxygen and other oxidizing gases
- Leak rate 1×10^{-4} , 10 times better than the industry standard for extreme applications
- Reduced internal stress zones
- Innovative valve core design
- Optimized bonnet assembly
- Enhanced Pressure Relief design
- Reliable dual O-ring and back-up ring design
- 100% helium leak tested @ 6000 PSI

Design Specifications		
	English	Metric
Maximum Working Pressure	6000 PSI	413 Bar
Burst Pressure	13,500 PSI	931 Bar
Leak Rate	1×10^{-4} atm cc/sec.	1×10^{-4} Bar mL/sec.
Operating Temperature	-50° F → +149° F	-46° C → +65° C
Operating Torque	10–20 in.-lbs.	1–2 N-m
Cv Flow Factor	Standard .69 CO ₂ / Manifold 1.23	
Cycle Life	2000 Cycles	2000 Cycles

For Product Markings Reference, see **A** on page 66.

MVHM Series Monel Valves

Materials of Construction	
Part Description	Materials of Construction
Handwheel	Aluminum ASTM A380
Locknut	Class 8 Steel with Nylon Insert
Stem	Monel N04405
Bonnet	Monel N04405
Backup Ring	PTFE (Upper), Ethylene Propylene (EPDM, Lower)
O-Ring	Ethylene Propylene (EPDM)
Thrust Washer	Delrin® 500AF
Seat Subassembly Plug	Leaded Naval Brass C48500
Seat Subassembly Seat	Nylon, Zytel 101
Body	Forged Monel N0400
Lubricants	Turmoxygen
Safety Subassembly Plug	Monel N04405
Safety Subassembly Disc	Bronze Copper C22000 or Nickel 201
Safety Subassembly Washer	Copper C11000
Safety Subassembly Fuse Metal	Eutectic Alloy

Standards Conformance	
CGA V-9	Standard for Gas Cylinder Valves
CGA S1.1	Standard for Pressure Relief Devices
CGA V-1	Compressed Gas Cylinder Valve Outlet and Inlet Specifications
ISO 10297	International Standard for Cylinder Valves Design Specifications
ISO 11363-1	25E Inlet Thread Specifications
AS2473	Australian Standard for Compressed Gas Cylinder Valves
A-A-59860	US General Services Administration Standards for Gas Cylinder Valves

Ordering Information					
Sherwood Part Number	CGA Outlet	Gas Service @ 70° F	Inlet	Safety	Outlet Thread Size
MVHM34725E4-65	347	3001–4700 PSI	25E	6750 PSI CG4	.825–14 NGO RH Ext.
MVHM34764-65-24	347	3001–4700 PSI	¾" NGT–24	6750 PSI CG4	.825–14 NGO RH Ext.
MVHM54064-32	540	0–3000 PSI	¾" NGT	3660 PSI CG4	.903–14 NGO RH Ext.
MVHM54064-35	540	0–3000 PSI	¾" NGT	3775 PSI CG4	.903–14 NGO RH Ext.
MVHM54064-38	540	4700–6400 PSI	¾" NGT	4000 PSI CG4	.903–14 NGO RH Ext.
MVHM70125E4-65	701	4700–6400 PSI	25E	6750 PSI CG4	1.103–14 NGO RH Ext.
MVHM70160	701	4700–6400 PSI	¾" NGT	No PRD	1.103–14 NGO RH Ext.
MVHM70164-65-24	701	4700–6400 PSI	¾" NGT–24	6750 PSI CG4	1.103–14 NGO RH Ext.
MVHM70264-85-24	702	4700–6400 PSI	¾" NGT–24	9000 PSI CG4	1.125–14 NGO RH Ext.

SVHM Series

Stainless Steel



SVHM

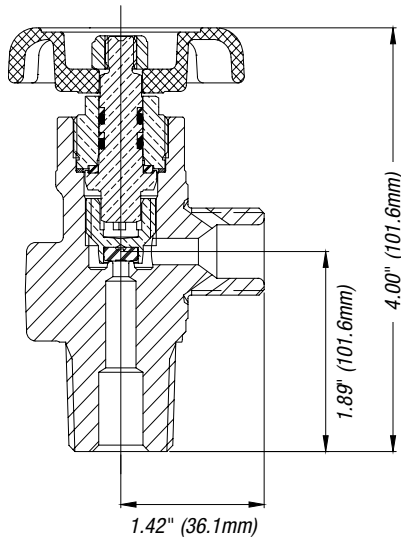

SVHM

Stainless-steel valves for challenging environments such as salt water and corrosive atmospheres like chemical processing plants.

Key Features & Benefits

- Designed to resist stress corrosion cracking as well as toxic atmospheres
- Corrosion resistant
- Compatible with high-pressure air and other oxidizing gases
- Leak rate 10 times better than the industry standard for extreme applications — 1×10^{-4}
- Reduced internal stress zones
- Innovative valve core design
- Optimized bonnet assembly
- Enhanced Pressure Relief design
- Reliable dual O-ring and back-up ring design
- 100% helium leak tested

Design Specifications		
	English	Metric
Maximum Working Pressure	6000 PSI	413 Bar
Burst Pressure	13,500 PSI	931 Bar
Leak Rate	1×10^{-4} atm cc/sec.	1×10^{-4} Bar mL/sec.
Operating Temperature	-50° F → +149° F	-46° C → +65° C
Operating Torque	10–20 in.-lbs.	1–2 N-m
Cv Flow Factor	Standard .69 CO ₂ /Manifold 1.23	
Cycle Life	2000 Cycles	2000 Cycles

For Product Markings Reference, see **A** on page 66.

SVHM Series

Stainless Steel Valves

Materials of Construction	
Part Description	Materials of Construction
Handwheel	Plated Aluminum ASTM A380
Locknut	316 Stainless Steel with Nylon Insert
Stem	316 Stainless Steel
Bonnet	316 Stainless Steel
Bonnet Gasket	Copper C11000
Backup Ring	PTFE (Upper), Ethylene Propylene (EPDM-Lower)
O-Ring	Ethylene Propylene (EPDM)
Thrust Washer	Delrin® 500AF
Seat Subassembly Plug	Leaded Naval Brass C48500
Seat Subassembly Seat	Nylon, Zytel 101
Body	Forged 316L Stainless Steel
Lubricants	Turmoxygen
Safety Subassembly Plug	316L Stainless Steel
Safety Subassembly Disc	Nickel 201
Safety Subassembly Washer	Copper C11000
Safety Subassembly Fuse Metal	Eutectic Alloy

Standards Conformance	
CGA V-9	Standard for Gas Cylinder Valves
CGA S1.1	Standard for Pressure Relief Devices
CGA V-1	Compressed Gas Cylinder Valve Outlet and Inlet Specifications
ISO 10297	International Standard for Cylinder Valves Design Specifications
ISO 11363-1	25E Inlet Thread Specifications
AS2473	Australian Standard for Compressed Gas Cylinder Valves
A-A-59860	US General Services Administration Standards for Gas Cylinder Valves

Ordering Information					
Sherwood Part Number	CGA Outlet	Gas Service @ 70° F	Inlet	Safety	Outlet Thread Size
SVHM34760	347	3001–4700 PSI	¾" NGT	No PRD	.825–14 NGO
SVHM34761-55	347	3001–4700 PSI	¾" NGT	5833 PSI CG-1	.825–14 NGO
SVHM34761-65	347	3001–4700 PSI	¾" NGT	6750 PSI CG-1	.825–14 NGO
SVHM34761-55-24	347	3001–4700 PSI	¾" NGT–24 Threads Oversize	5833 PSI CG-1	.825–14 NGO
SVHM34761-65-24	347	3001–4700 PSI	¾" NGT–24 Threads Oversize	6750 PSI CG-1	.825–14 NGO

BV Series

Hi/Lo Valves with Built-In Regulators

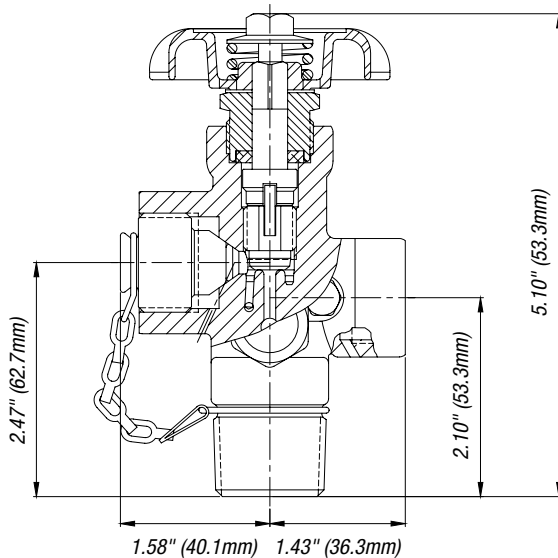
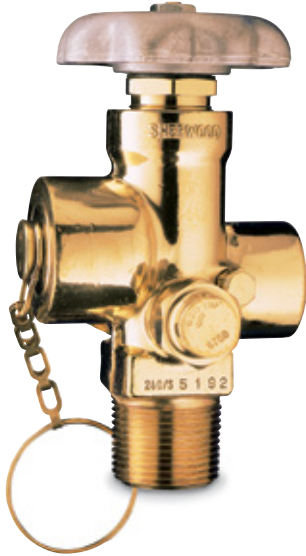

BV6861-65-XXXT

Designed for use in larger capacity lightweight 4500 PSI cylinders, the BV Series features an integral regulator that reduces gas pressure on the 3000 PSI max outlet to 700–1000 PSI, enabling field use of a common UL® Rated 3000 PSI regulator.

Key Features & Benefits

- Unique dual outlet design enables use of lower or higher cylinder Working Pressure from the same valve/cylinder package
- Provides quick fill capability — no special filling or withdrawal adapters needed
- Strong, durable forged brass body manufactured by Sherwood to specifications stricter than most commercial forging specifications
- High-temperature aluminum alloy handwheel with large drainage holes
- Integral stainless steel tang helps prevent internal stem breakage
- Durable lower plug made of tough naval brass resists wear
- Lower plug is PTFE coated to add lubricity, which minimizes seizing and galling especially under high-pressure operation
- Internally threaded chamber design promotes longer life and helps protect valve body chamber threads from damage
- Nickel 201 rupture disc resists premature rupture that may be caused by corrosive ambient environments
- Inert PTFE packing provides leak-free stem seal, long cycle life and resistance to corrosion
- Regulator designed for long service life and tested to in excess of 16,000 cycles
- Pressure Relief Device strategically located in regulated pressure outlet prevents cylinder pressure from reaching downstream equipment
- Pressure Relief Device supplied standard for 4500 PSI cylinder with a test pressure of 1.5 times Working Pressure
- Regulated Outlet Pressure Relief Device rupture pressure is 2800–3000 PSI
- High-pressure outlet plug removal tool (Part Number 680PW-2) supplied separately to cylinder filling plants only

For Product Markings Reference, see **F** on page 66.

BV Series

Hi/Lo Valves with Built-In Regulators

BV Series Regulated Outlet Flow

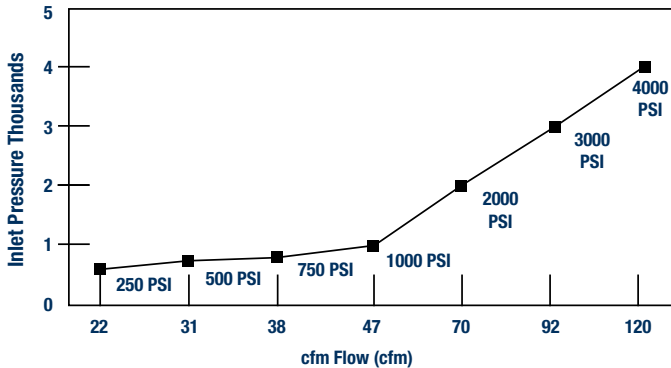

Design Specifications		
	English	Metric
Test Pressure	4500 PSI	310 Bar
Proof Pressure	20,000 PSI	1379 Bar
Regulated Outlet Pressure @ 4500 PSI inlet Pressure	700–1100 PSI	48–76 Bar
Operating Temperature Range	-50° F → +120° F	-45° C → +49° C
Storage Temperature Range	-65° F → +155° F	-54° C → +68° C
Minimum Cycle Life	5000 Cycles	5000 Cycles
Operating Torque	20–30 in.-lbs.	2.2–3.4 N-m
Closing Torque	10–20 in.-lbs.	1.1–2.2 N-m
Bonnet Installation Torque	70–80 ft.-lbs.	95–108.4 N-m
Safety Cap Installation Torque	30–40 ft.-lbs.	40.6–54.2 N-m
Stem Nut Installation Torque	Nut flush with top of stem	Nut flush with top of stem
650-19 Series PRD Installation Torque	30–40 ft.-lbs.	40.3–53.7 N-m
4000-60-29 PRD Installation Torque	70–80 in.-lbs.	94.3–107.7 N-m

Parts Breakdown for BV Series

A. Handwheel Nut	47-1003
B. Handwheel Spring	45-1012
C. Handwheel	1401
D. Handwheel Washer	1413
E. Bonnet	1250-2
F. Packing	1250-6
G. Stem & Tang Assembly	1250-30
H. Plug & Seat Assembly	1250B-40A
I. Piston & Spring Assembly	Not sold separately
J. Plug Assembly	680P-20 (Inert Gases) 701P-20 (Oxygen)
K. Safety Plug Assembly	4000-60-29
L. Safety Cap Assembly	650-19F9-65

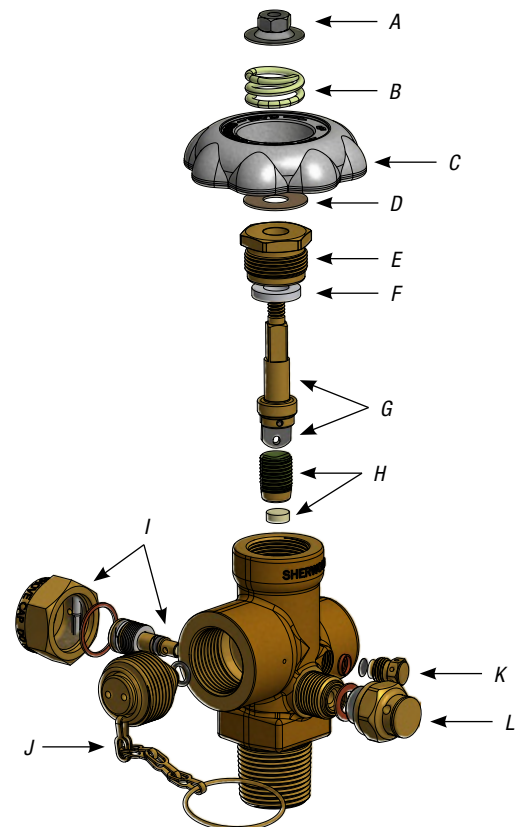

Industrial Gas Valves

BV Series

Hi/Lo Valves with Built-In Regulators

Materials of Construction		
Sherwood Part Number	Part Description	Materials of Construction
N/A	Body	Brass C37700
N/A	Filter	Sintered Bronze 65–100 Micron
1250B-40 or 1250B-40A	Plug and Seat Assembly Plug Seat	Nylon Zytel 101 Naval Brass C48500 PTFE Coated
1250-2	Bonnet	Brass C37700
1401	Handwheel	Aluminum A380
47-1003	Nut	AISI 1010 Steel Corrosion Protective Coating
45-1012	Spring	Hard Drawn Spring Steel Cadmium or Zinc Plate
1413	Washer, Handwheel	High Density Gray Fiber Paraffin Coated
1250-6	Packing	Virgin PTFE
680P-20 (Inert Gases) 701P-20 (Oxygen)	Plug Assembly Ring Chain Plug O-Ring	Brass Wire Brass Brass C36000 Buna-N (680P-20) or Viton® (701P-20)
N/A	Pin	Carbon Steel C1215 Zinc Plated
N/A	Piston & Spring Assembly Piston Seat O-Ring Back-up Ring Spring Shim	Brass C36000 ½ Hard PTFE Viton® 75+ or -5 Durometer PTFE Stainless Steel 301 Passivated Brass C26000
N/A	Gasket	Copper Annealed Soft
4000-60-29	Safety Plug Assembly Body Retainer Burst Disc	Brass C36000 Copper C11000 Nickel 201
650-19F9-65	Safety Cap Assembly Gasket Burst Disc Safety Cap	Copper CDA 110 Nickel 201 Brass C36000

Standards Conformance	
CGA V-9	Standard for Gas Cylinder Valves
CGA S-1.1	Standard for Pressure Relief Devices
CGA V-1	Compressed Gas Cylinder Valve Outlet and Inlet Connections
A-A-59860	U.S. General Services Administration Standards for Gas Cylinder Valves

Ordering Information						
Sherwood Part Number	Gas Service	High Pressure Fill Port Connection	Regulated Outlet Connection	Regulated Outlet Pressure	Inlet	Cap & Plug
BV6861-STD-65-580T	Inert Gases	CGA 680 (high) .965–14 NGO RH Int.	CGA 580 (low)	700–1100 PSI @ 4500 PSI Inlet	¾"–14 NGT	Yes
BV6861-65-580T	Inert Gases	CGA 680 (high) .965–14 NGO RH Int.	CGA 580 (low)	700–1100 PSI @ 4500 PSI Inlet	¾"–14 NGT 24 Threads Oversize	Yes
BV6861-65-580TL	Inert Gases	CGA 680 (high) .965–14 NGO RH Int.	CGA 580 (low)	700–1100 PSI @ 4500 PSI Inlet	¾"–14 NGT	No
BV70161-65-540	Oxygen	CGA 701 (high) 1.103–14 NGO RH Ext.	CGA 540 (low)	700–1100 PSI @ 4500 PSI Inlet	¾"–14 NGT 24 Threads Oversize	Yes
680PW-2	Spanner Wrench Tool					



1206A Series

Packed Wrench-Operated Valves for Anhydrous Ammonia Applications



1206AX5

Designed for anhydrous ammonia applications, including commercial refrigeration, metal treating and chemical manufacturing.

Key Features & Benefits

- One-piece lead carbon steel, case-hardened, nickel-plated stem provides positive shut-off in corrosive gas service with exceptional durability
- One-piece PTFE packing promotes easy operation while providing a durable leak-resistant stem seal
- Designed to ensure a safe, long, trouble-free life under all service conditions
- Meets CGA standards
- 1206AX5 compatible with both CGA 705 and 240 outlets
- 1206AX9 compatible with CGA 240 outlet only
- Inlet Tap 1/4"-18 NPT

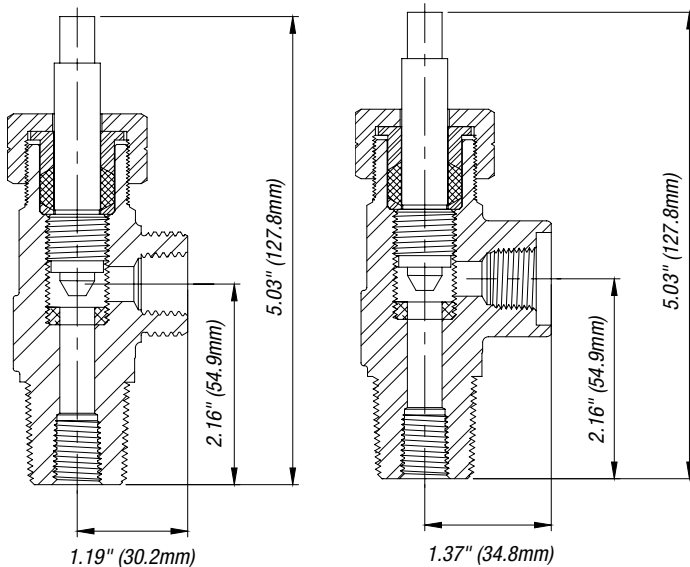

1206AX5

1206AX9

Design Specifications

	English	Metric
Maximum Working Pressure	3000 PSI	207 Bar
Burst Pressure	15,000 PSI	1034 Bar
Leak Rate	1x10 ⁻⁵ atm cc/s	1x10 ⁻⁵ Bar mL/sec
Operating Temperature	-50° F → +130° F	-45° C → +54° C
Operating Torque	5–6.5 ft.-lbs.	6.8–8.8 N-m
Closing Torque	15 ft.-lbs.	20.3 N-m
Cv Flow Factor	0.733	0.733
Cycle Life	1000 Minimum	1000 Minimum

For Product Markings Reference, see **D** on page 66.

Industrial Gas Valves

1206A Series

Packed Wrench-Operated Valves for Anhydrous Ammonia Applications

Materials of Construction		
Sherwood Part Number	Part Description	Materials of Construction
P1206A-2C	Stem	12L14 Carbon Steel with Nickel Plating
P1206-4C	Packing Nut	12L14 Carbon Steel with Zinc Plating
P1206-3C	Packing Gland	12L14 Carbon Steel with Zinc Plating
P5325-6T	Packing	PTFE
P1206-5C	Packing Washer	12L14 Carbon Steel with Zinc Plating
N/A	Seat	Tin (SN)
N/A	Body	303 Stainless Steel

Standards Conformance	
CGA V-9	Standards for Gas Cylinder Valves
CGA S1.1	Standards for Pressure Relief Devices
CGA V-1	Compressed Gas Cylinder Valve Outlet
A-A-59860	US General Services Administration Standards for Gas Cylinder Valves

Ordering Information		
Sherwood Part Number	Description	CGA Outlet
1206AX5	Packed Ammonia Cylinder Valve	705, 240
1206AX9	Packed Ammonia Cylinder Valve with Lead Washer Recess	240
628X1	Ammonia Yoke	845
5877	Adapter	845



628X1



5877

For Product Markings Reference, see **D** on page 66.

AV Series

Small Cylinder Acetylene Wrench-Operated Valves



AV5160WB

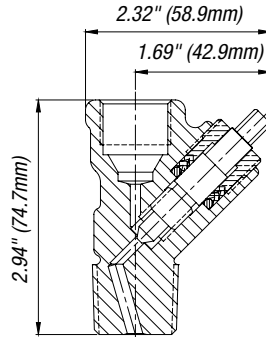

AVB521

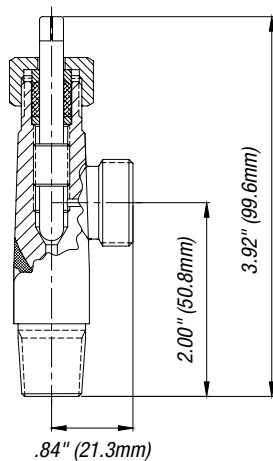

AVMC201

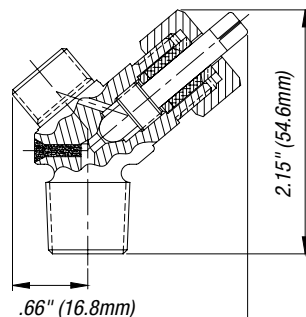

Key Features & Benefits

AV5160WB

- Use with 390 cu. ft. capacity (WB style) cylinders
- Enables easy access and operation within the cylinder collar

AVB521

- Use with 40 cu. ft. capacity (B style) cylinders
- Provides rugged durability in construction and field servicing applications
- Enables positive shut-off

AVB521S

- Use in manifold applications
- Clearly labeled "Manifold" with red bonnet nut
- Designed without fuse metal (no internal PRD)

AVB521SM

- Use in manifold applications in corrosive environments
- Features stainless steel stem
- Clearly labeled "Manifold" with red bonnet nut
- Designed without fuse metal (no internal PRD)

AVMC201

- Use with 10 cu. ft. capacity (MC style) cylinders
- Ideal for brazing and cutting applications
- Enables positive shut-off

Design Specifications

		English	Metric
AV Series	Operating Torque	4–6 in.-lbs	.4–.7 N-m
AVB and AVMC Valves	Closing Torque	6–10 in.-lbs.	.7–1.1 N-m
AVB and AVMC Valves	Bonnet Nut	105–115 in.-lbs.	11.8–13 N-m
AV5160WB Only	Closing Torque	14–16 in.-lbs.	1.6–1.8 N-m
AV5160WB Only	Packing Nut	120–180 in.-lbs.	13.5–20.3 N-m

For Product Markings Reference, see **F** on page 66.

Acetylene Valves

AV Series

Small Cylinder Acetylene Wrench-Operated Valves

Materials of Construction		
Sherwood Part Number	Part Description	Materials of Construction
AVMC201		
N/A	Lubricant	Dow Corning 55M
2000-9B35	Packing Nut	Brass C36000
2000-9B30	Packing Gland	Brass C36000
2000-9B20	Packing	PTFE
2000-B75	Packing Washer	Brass C36000
5-2000A-2B00	Needle	Steel, Zinc Plated
N/A	Body	Brass C37700 & Fuse Metal
AVB521SM		
J26005-43B	Retaining Ring	Stainless Steel
5201-9B70	Strainer	Monel
N/A	Lubricant	Dow Corning 55M
2000-9B35R	Packing Nut	Brass C36000
2000-9B30	Packing Gland	Brass C36000
2000-9B20	Packing	PTFE
2000-9B75	Packing Washer	Brass C36000
19-5200-2B00	Needle	Stainless Steel
N/A	Body	Brass C37700
AVB521S		
J26005-43B	Retaining Ring	Stainless Steel
5201-9B70	Strainer	Monel
N/A	Lubricant	Dow Corning 55M
2000-9B35R	Packing Nut	Brass C36000
2000-9B30	Packing Gland	Brass C36000
2000-9B20	Packing	PTFE
2000-9B75	Packing Washer	Brass C36000
5-5200A-2B00	Needle	Steel, Zinc Plated
N/A	Body	Brass C37700
AV5160WB		
N/A	Lubricant	Dow Corning 55M
8830-6008	Packing	PTFE
5106-9B35	Bonnet	Brass C36000
19-5106-2B00	Needle	Stainless Steel
5101-9B75	Adapter	Brass C36000
N/A	Body	Brass C37700
AVB521		
N/A	Lubricant	Dow Corning 55M
2000-9B35	Packing Nut	Brass C36000
2000-9B30	Packing Gland	Brass C36000
2000-9B20	Packing	PTFE
2000-9B75	Packing Washer	Brass C36000
5-5200A-2B00	Needle	Steel, Zinc Plated
N/A	Body	Brass C37700 & Fuse Metal

Standards Conformance	
CGA V-9	Standards for Gas Cylinder Valves
CGA S1.1	Standards for Pressure Relief Devices
A-A-59860	US General Services Administration Standards for Gas Cylinder Valves

Ordering Information				
Sherwood Part Number	CGA	Outlet Thread Size	Inlet Thread Size	Fusible Metal
AV5160WB	510	.885-14 NGO LH Int.	3/4"-14 NGT	—
AVB521	520	.895-18 NGO RH Ext.	3/8"-18 NGT	212° F
AVB521S (Manifold)	520	.895-18 NGO RH Ext.	3/8"-18 NGT	None
AVB521SM (Manifold)	520	.895-18 NGO RH Ext.	3/8"-18 NGT	None
AVMC201	200	.625-20 NGO RH Ext.	3/8"-18 NGT	212° F

AV-HW Series

Small Cylinder Acetylene Handwheel-Operated Valves



AVB521HW

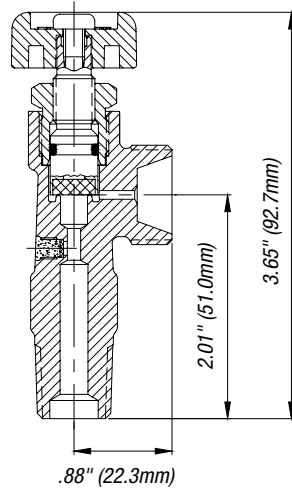

AVB521HWM

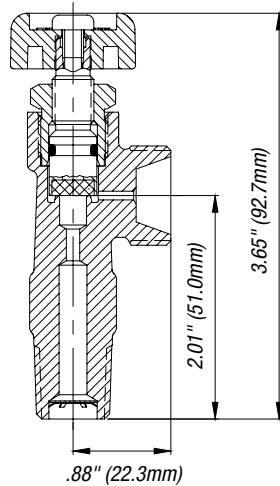

AVMC201HW

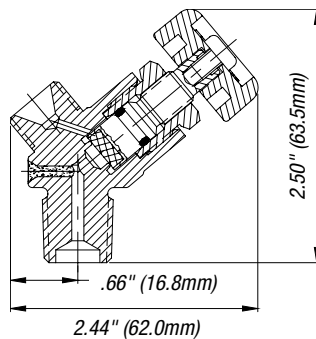

Key Features & Benefits

All AV-HW series valves are offered with protected internal bonnet design.

AVB521HW

- Use with B style cylinders
- Handwheel enables ease of use in transportation and in the field
- Provides rugged durability for construction and field servicing applications

AVB521HWM

- Use in manifold applications
- Clearly labeled "Manifold" with red handwheel
- Enables ease of use in transportation and in the field
- Designed without fuse metal (no internal PRD)

AVMC201HW

- Use with 10 cu. ft. capacity (MC style) cylinders
- Enables ease of use in transportation and in the field
- Ideal for brazing and cutting applications

Design Specifications

	English	Metric
Maximum Working Pressure	500 PSI	34 Bar
Burst Pressure	1125 PSI	77 Bar
Leak Rate	1x10 ⁻³ atm cc/sec	1x10 ⁻³ Bar mL/sec
Operating Torque	10–20 in.-lbs	1–2 Nm
Cv Flow Factor	Standard (.078" Thru Hole) .15	
Cycle Life	2000 Minimum	2000 Minimum

For Product Markings Reference, see **C** on page 66.

Acetylene Valves

AV-HW Series

Small Cylinder Acetylene Handwheel-Operated Valves

Materials of Construction	
Part Description	Materials of Construction
Handwheel	Aluminum A380
Screw	Zinc Plated Alloy Steel
Stem	Brass C36000
Bonnet	Brass C36000
O-Ring	Ethylene Propylene (EPDM)
Seat	Nylon, Zytel 101
Body	Forged Brass C37700
Lubricants	Christo-Lube
Fuse Metal	Bismuth, Lead, Cadmium, Tin
Retaining Ring (AVB521HWM)	PH15-7 MO Stainless Steel
Strainer (AVB521HWM)	Wire Monel Cloth

Standards of Conformance	
CGA V-9	Standard for Gas Cylinder Valves
ISO10297	International Standard for Cylinder Valves Design Specifications
CGA V-1	Compressed Gas Cylinder Valve Outlet
CGA S1.1	Standard for Pressure Relief Devices
A-A-59860	US General Services Administration Standards for Gas Cylinder Valves

Ordering Information				
Sherwood Part Number	CGA	Outlet Thread Size	Inlet Thread Size	Fusible Metal
AVB521HW	520	.895-18 NGO RH Ext.	3/8"-18 NGT	212° F
AVB521HWM (Manifold)	520	.895-18 NGO RH Ext.	3/8"-18 NGT	None
AVMC201HW	200	.625-20 NGO RH Ext.	3/8"-18 NGT	212° F

AV-HW Kits	
Sherwood Part Number	Description
78-2058-7-KIT	Gold Handwheel & Screw (25 pieces)
79-2058-7-KIT	Red Handwheel & Screw (25 pieces)
3329-13Y-KIT	Replacement Stem Assembly Kit (25 pieces)

GV Acetylene Series

Large Cylinder Acetylene Valves



GV51060

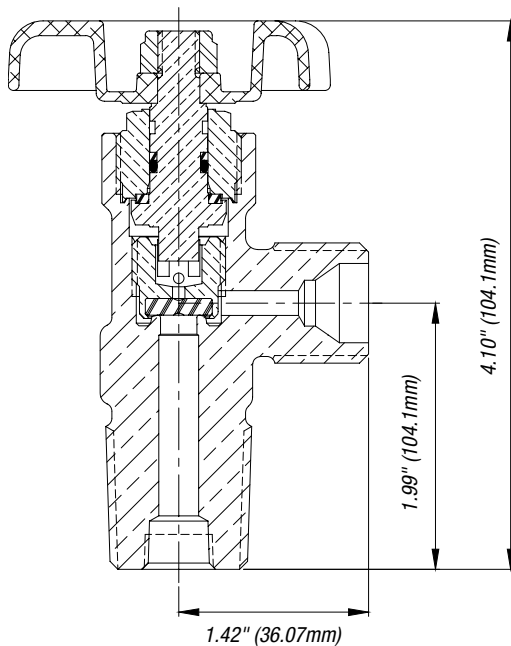

GV51060

Key Features & Benefits

- Durable forged brass body, precisely machined internal components and design elements meet the most stringent international valve performance standards
- High-temperature aluminum alloy handwheel with large drainage holes
- 100% helium leak tested
- Designed with low-torque operation for easy hand use
- Durable lower plug made of tough naval brass resists wear
- Precise quality machining results in exceptional finishes for low-torque sealing
- Metal-to-metal seal below bonnet threads prevents pressure accumulation at top of valve body
- High durometer back-up ring prevents extrusion of O-ring in extreme applications
- Peroxide curing of elastomeric seals enhances valve longevity
- Direct drive stem design with optimized single O-ring seal reduces friction and operates at exceptionally low torque levels
- For more information, refer to GV Design Specifications on **page 3**

Ordering Information			
Sherwood Part Number	CGA Outlet Number	Outlet Thread Size	Inlet Thread Size
GV30040	300	.825"-14 NGO RH Ext. (Commercial)	½"-14 NGT
GV30060	300	.825"-14 NGO RH Ext. (Commercial)	¾"-14 NGT
GV30080	300	.825"-14 NGO RH Ext. (Commercial)	1"-11½ NGT
GV41060	410	.850"-14 NGO LH Ext. (Canadian Std.)	¾"-14 NGT
GV51040	510	.885"-14 NGO LH Int. (POL)	½"-14 NGT
GV51060	510	.885"-14 NGO LH Int. (POL)	¾"-14 NGT
GV51080	510	.885"-14 NGO LH Int. (POL)	1"-11½ NGT

For Product Markings Reference, see **A** on page 66.



Acetylene Valves

GVT Series
Vertical Outlet Acetylene Valves



GVT51060

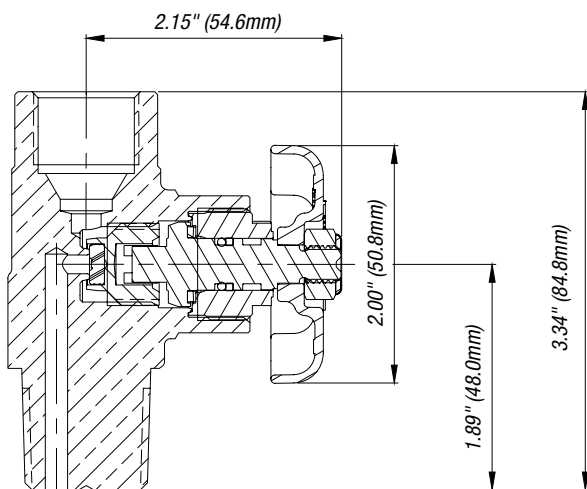

GVT51060

Standards Conformance	
CGA V-9	Standard for Gas Cylinder Valves
CGA S-1.1	Standard for Pressure Relief Devices
CGA V-1	Compressed Gas Cylinder Valve Outlet and Inlet Connections
A-A-59860	US General Services Administration Standards for Gas Cylinder Valves

Ordering Information			
Sherwood Part Number	CGA Outlet	Outlet Thread Size	Inlet Thread Size
GVT51060	510	.885-14 NGO LH Int.	¼"-14 NGT
GVT30060	300	.825-14 NGO RH Ext.	¼"-14 NGT

Key Features & Benefits

- Heavy-duty brass forged body
- O-ring designed for leak integrity and easy operation
- Handwheel eliminates interference with cylinder collar
- Easy-to-read valve markings roll stamped on outlet neck
- Soft seat design provides positive shut-off

Design Specifications		
	English	Metric
Max. Working Pressure	500 PSI	34.5 Bar
Burst Pressure	15,000 PSI	1034 Bar
Leak Rate	1x10 ⁻³ atm cc/sec.	1x10 ⁻⁵ Bar mL/sec.
Temperature Range		
Operating	-50° F → +149° F	-46° F → +65° F
Cycle Life Min.	2000 Cycles	2000 Cycles
Max. Operating Torque	10-20 in.-lbs.	1.1-2.2 N-m
Closing Torque	20-30 in.-lbs.	2.2-3.3 N-m
Cv Flow Factor	.69	.69
Seat Orifice	.158 in.	4.0 mm

Materials of Construction		
Sherwood Part Number	Part Description	Materials of Construction
3329-8	Handwheel	Aluminum ASTM SC84B
1251-6	Locknut	Class 8 Steel with Nylon Insert
1400-3	Stem	Brass C36000
N/A	Bonnet	Brass C36000 H02 Temper ½ Hard or CW614N Brass (European)
N/A	Backup O-Ring	Ethylene Propylene (EPDM)
G011EP	O-Ring	Ethylene Propylene (EPDM)
N/A	Thrust Washer	Delrin® 500AF
	Plug and Seat Subassembly	
1400-40	Plug	Leaded Naval Brass C48500
	Seat	Nylon, Zytel 101
N/A	Body	Forged Brass C37000
N/A	Lubricants	Christo-Lube

For Product Markings Reference, see **A** on page 66.



KVAB Series

Post Medical Valves

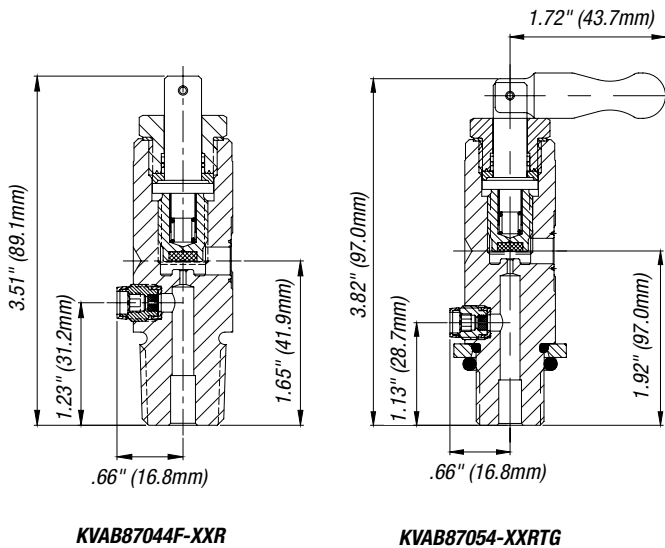

Post-type medical valves for "F" and "D" type cylinders and used for all CGA-860 yokes.

Key Features & Benefits

- Inert PTFE packing provides leak-free stem seal, long cycle life and resistance to corrosion
- Secondary O-ring helps to provide a secure seal under vacuum purging and low-pressure operation
- Strong, durable body is made from extruded brass rod and coated with a protective chrome finish
- Chamber design protects threads and stem from damage
- Exceptional machining finishes for low-torque sealing and long packing life
- Durable lower plug is made of tough naval brass and coated with PTFE for lubricity
- Copper sealing gasket provides permanent, leak-resistant bonnet seal
- Pressure Relief Device is an integrated assembly to ensure proper assembly and to resist tampering
- Designed for use with all yokes made to CGA 860 drawing specifications
- Available in wrench or toggle type
- Nominal stroke is 1.5 turns, full flow at 1/3 turn
- Cleaned for oxygen service and oil free per CGA G-4.1
- For Date Code Tables, see **pages 67–68**

Design Specifications		
	English	Metric
Maximum Working Pressure	3000 PSI	207 Bar
Burst Pressure	12,000 PSI	827 Bar
Operating Temperature Range	-50° F → +149° F	-45° C → +65° C
Storage Temperature Range	-65° F → +155° F	-54° C → +68° C
Leak Rate Internal/External	1x10 ⁻³ cc/sec.	1x10 ⁻³ Bar mL/sec.
Cv Flow Factor	Standard: .102	
Minimum Cycle Life	5000 Cycles	
Opening Torque	8–10 in.-lbs	1–1.1 N-m
Closing Torque	8–10 in.-lbs	1–1.1 N-m
Operating Torque	10–30 in.-lbs	1.1–3.4 N-m
Bonnet Torque	25–30 ft.-lbs.	33.9–40.6 N-m
PRD Torque	50–65 in.-lbs.	5.6–7.3 N-m

Standards Conformance	
CGA V-9	Standard for Compressed Gas Cylinder Valves
CGA S1.1	Standard for Pressure Relief Devices
CGA V-1	Compressed Gas Cylinder Valve Outlet and Inlet Specifications
A-A-59860	US General Services Administration Standards for Gas Cylinder Valves



Medical Valves

KVAB Series

Post Medical Valves

Materials of Construction		
Sherwood Part Number	Part Description	Materials of Construction
N/A	Body	Brass C36000, Chrome Plated
6519	Packing Washer	Copper
6503SH	Bonnet & Stem Assembly	Bonnet Brass C36000, Nickel Plated
Stem		Brass C36000, Nickel Plated
Packing		PTFE
O-Ring		Viton®
Backup Ring		PTFE
6527SH	Spring	316 Stainless Steel
6507A-17N	Seat Assembly	Plug Leaded Naval Brass C48500, PTFE Coated
Seat Insert		Nylon, Zytel 101
1-K655B-2	Flange Ring	Brass C36000, Nickel Plated
G908H	Flange O-Ring	Viton®
6513MFA-XXKIT (25 pieces) 6513MFB-XXKIT (25 pieces)	Safety Assembly	165° Eutectic Alloy
9-K655B-2	Pressure Relief Device	Plug Brass C36000, Nickel Plated
Disc		Nickel
Gasket		Nylon, Zytel 101
9-4000-60-XX KIT	Pressure Relief Device	Plug Brass C36000, Nickel Plated
Disc		Nickel
Gasket		Nylon, Zytel 101
1-KTS-1C	Toggle	Diecast Aluminum, Chrome Plated
J250608B (old style)	Toggle Pin	303 Stainless Steel
J33-09308SS (new style)	Toggle Pin	303 Stainless Steel

Inlet O-Ring for Straight Threaded KVAB Series Medical Valves

Sherwood Part Number	Inlet Size	Material
G210J	.750-16 UNF	Viton®
G210T	.750-16 UNF	PTFE

Lubricants

KVAB valves require no lubrication on any internal component except for the stem O-ring and the copper gasket. The lubrication used on these parts MUST be oxygen compatible. Sherwood recommends the use of Christo-Lube, Fluorolube® GR362, Krytox® 240AB or an equivalent lubricant.

KVAB Series

Post Medical Valves

For further information, see Data Code Tables on **page 67–68**.

Ordering Information					
Sherwood Part Number	Gas Service	Safety	CGA Outlet	Pin Indexing Hole Numbers	Inlet Thread Size
KVAB87044F-XX KVAB87054-XX	Oxygen	CG-4	870	Pins #2 and #5	½"–14 NGT .750–16 UNF-2A
KVAB88044F-XX KVAB88054-XX	Oxygen and Carbon Dioxide Mixtures	CG-4	880	Pins #2 and #6	½"–14 NGT .750–16 UNF-2A
KVAB89044F-XX KVAB89054-XX	Oxygen and Helium Mixtures	CG-4	890	Pins #2 and #4	½"–14 NGT .750–16 UNF-2A
KVAB91041-XX KVAB91051-XX	Nitrous Oxide	CG-1	910	Pins #3 and #5	½"–14 NGT .750–16 UNF-2A
KVAB93044F-XX KVAB93054-XX	Helium	CG-4	930	Pins #4 and #6	½"–14 NGT .750–16 UNF-2A
KVAB94041-XX KVAB94051-XX	Carbon Dioxide	CG-1	940	Pins #1 and #6	½"–14 NGT .750–16 UNF-2A
KVAB95044F-XX KVAB95054-XX	Air	CG-4	950	Pins #1 and #5	½"–14 NGT .750–16 UNF-2A
KVAB96044F-XX KVAB96054-XX	Nitrogen	CG-4	960	Pins #1 and #4	½"–14 NGT .750–16 UNF-2A
KVAB96541-XX KVAB96554-XX	Nitrous Oxide and Oxygen Mixtures	CG-1 CG-4	965	Pin #7	½"–14 NGT .750–16 UNF-2A
KVAB97344-XX KVAB97354-XX	Medical Gas Mixtures	CG-4	973	Pins #11 and #24	½"–14 NGT .750–16 UNF-2A

OPTIONS

- All valves are supplied with rupture discs rated for 2015 PSI Working Pressure cylinders. Rupture discs rated for other Working Pressures available on request.
- To order ⅛"–27 NPT modified gauge port, add "G" to end of Part Number (e.g. KVAB87054-32G).
- To order rugged diecast aluminum toggle lever, add "TG" to end of Part Number (e.g. KVAB87054-32 becomes KVAB87054-32TG).
- To order PTFE inlet O-ring, add "R" to end of Part Number (e.g. KVAB87054-32 becomes KVAB87054-32R).
THIS OPTION ONLY AVAILABLE ON .750–16 UNF-2A INLET VALVES. XX = PRD Safety

Key Replacement Parts						
Pressure Relief Device Sherwood Part Number		-XX	Cylinder Working Pressure	Color-Coded Ring to Designate Pressure (6513 MFX only)	Disc Rupture Range PSI @ 160° F	
CG-1 No Fuse Metal	CG-4 165° F Fuse Metal				Min.	Max.
<i>Pressure Relief Devices*</i>						
9-4000-60-28	6513MFA-28	-28	1800 PSI	Orange	2700	3000
9-4000-60-32	6513MFB-32	-32	2015 PSI	None	3025	3360
9-4000-60-48	6513MFA-48	-48	3000 PSI	Black	4500	5000

* Available in Pressure Relief Device Kits (see below).

Pressure Relief Device Kits	
Sherwood Part Number	Description
6513MFA-28KIT	25 PRD Assemblies
6513MFB-32KIT	25 PRD Assemblies
6513MFA-48KIT	25 PRD Assemblies



TL-KTS-C
Tool for Insertion/Crimping to replace
KVAB toggle 1-KTS-1C and toggle pin J33-09308SS

Medical Valves

KVMB Series

Post Medical Valves for Use in Magnetic Resonance Imaging (MRI) Environments

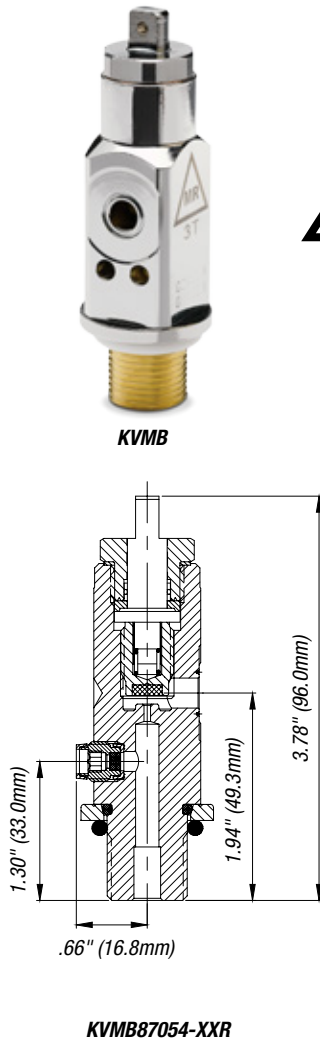

KVMB

KVMB87054-XXR

Key Features & Benefits

- Special construction process significantly reduces magnetic attraction
- Meets all known tests for MRI-conditional components used in conjunction with a magnetic resonance imager for Level 3 Tesla requirements
- Clearly identified for hospital settings
- ASTM standard F 2503-05 marking
- Inert PTFE packing provides leak-free stem seal and resistance to corrosion
- Secondary O-ring helps to provide a secure seal under vacuum purging and low-pressure operation
- Strong, durable body is made from extruded brass rod and coated with a protective chrome finish
- Chamber design protects threads and stem from damage
- Exceptional machining finishes for low-torque sealing and long packing life
- Durable lower plug is made of tough naval brass and coated with PTFE for lubricity
- Copper sealing gasket provides permanent, leak-resistant bonnet seal
- Pressure Relief Device (PRD) is a single unit to ensure proper assembly and to resist tampering
- For use with all yokes made to CGA 860 drawing specifications
- Available in wrench, toggle or handwheel type
- Nominal stroke is 1.5 turns, full flow at $\frac{1}{3}$ turn
- Cleaned for oxygen service and oil free per CGA G-4.1
- For Date Code Tables, see **pages 67–68**
- Refer to KVAB Series for more design specifications

Ordering Information

Sherwood Part Number	Gas Service	Safety	CGA Outlet	Pin Indexing Hole Numbers	Inlet Thread Size
KVMB95054-XX	Air	CG4	950	Pins #1 and #5	.750–16 UNF-2A
KVMB91051-XX	Nitrous Oxide	CG1	910	Pins #3 and #5	.750–16 UNF-2A
KVMB87054-XX	Oxygen	CG4	870	Pins #2 and #5	.750–16 UNF-2A

OPTIONS

- To order rugged diecast aluminum toggle lever, add "TG" to end of Part Number (e.g. KVMB87054-32R) becomes (KVMB87054-32RTG).
- To order PTFE inlet O-ring, add "R" to end of Part Number (e.g. KVMB87054-32 becomes KVMB87054-32R). THIS OPTION ONLY AVAILABLE ON .750–16 UNF-2A INLET VALVES.
XX= PRD Safety

GV MRI Series

Global Valves for Use in MRI Environments

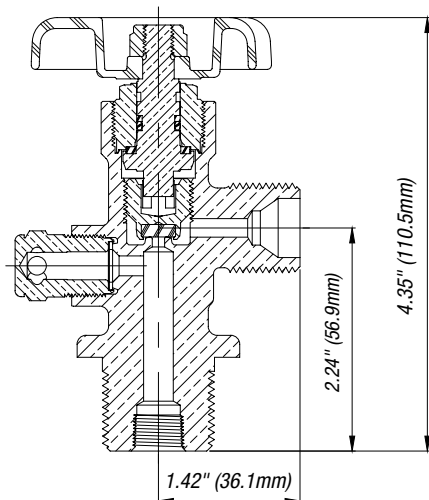

GVXX51-XXMRI

High Capacity Oxygen Valve designed for use in Magnetic Resonance Environments (MRI), specifically when installed on high-capacity aluminum cylinders.

Key Features & Benefits

- Supports aluminum cylinder capacity to 265 cu. ft. with various straight-threaded inlet sizes to fit your needs
- Special construction process significantly reduces magnetic attraction
- Tested and meets all known tests for MRI-compatible components used in conjunction with a magnetic resonance imager for Level 3 Tesla requirements
- Clearly identified for hospital settings with ASTM standard F 2503-05 markings
- Cleaned for oxygen service and oil free per CGA G-4.1
- Automated assembly and testing processes ensure exceptional quality
- 100% helium leak tested
- Heavy-duty forged brass body for durability and high pressure
- Precisely machined internal components meet the most stringent international valve performance standards
- Pressure Relief Device (PRD) is a unitized plug design which provides excellent flow characteristics, ensures proper assembly and tamper resistance
- Metal-to-metal seal below bonnet threads prevents pressure in the threads at the top of the valve body
- Direct-drive stem design with optimized O-ring (GV) or double O-ring (GVHM) seal reduces friction and operates at exceptionally low torque levels
- Inlet and outlet thread configurations are available for a broad spectrum of customer, country and code specifications
- Tapped for dip tube as required
- For more information, refer to GV Design Specifications on [page 3](#)

For Product Markings Reference, see [A](#) on [page 66](#).

Ordering Information

Sherwood Part Number	Gas Service @ 70° F	CGA	Outlet Thread Size	Inlet Thread Size
GV32051-XXMRI	0–3000 PSI	320	.825–14 NGO RH Ext.	1½–12 UNF
GV32051-XX-75MRI	0–3000 PSI	320	.825–14 NGO RH Ext.	¾–16 UNF
GV32651-XXMRI	0–3000 PSI	326	.825–14 NGO RH Ext.	1½–12 UNF
GV32651-XX-75MRI	0–3000 PSI	326	.825–14 NGO RH Ext.	¾–16 UNF
GV34651-XXMRI	0–3000 PSI	346	.825–14 NGO RH Ext.	1½–12 UNF
GV34651-XX-75MRI	0–3000 PSI	346	.825–14 NGO RH Ext.	¾–16 UNF
GV54051-XXMRI	0–3000 PSI	540	.903–14 NGO RH Ext.	1½–12 UNF
GV54051-XX-75MRI	0–3000 PSI	540	.903–14 NGO RH Ext.	¾–16 UNF
GV58051-XXMRI	0–3000 PSI	580	.965–14 NGO RH Int.	1½–12 UNF
GV58051-XX-75MRI	0–3000 PSI	580	.965–14 NGO RH Int.	¾–16 UNF

Medical Valves

OxyGen I Series

Oxygen Valves with Integrated Pressure Regulators

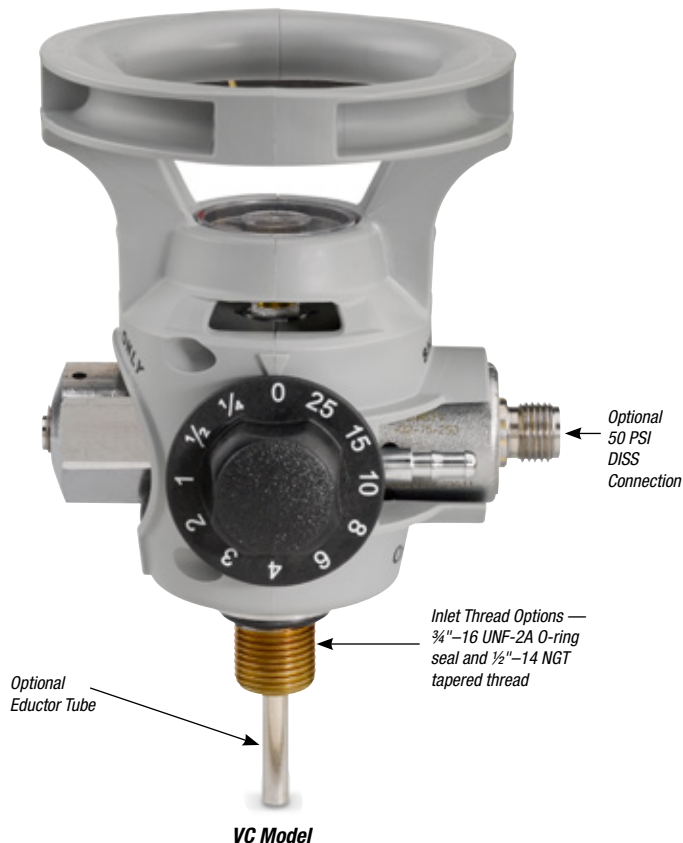

Key Features & Benefits

Compact, Easy-to-Use Design

- Designed for ambulatory service applications, combines on/off with reduced pressure for direct patient care
- A 35% lower profile than comparable models provides more efficient racking and storage capabilities
- 15 to 25% lighter weight than comparable models
- Ergonomically designed shroud with carrying handles improves mobility and reduces user fatigue
- Shroud circumference is sized to fit within the footprint diameter of standard Medical-E cylinders
- Pressure gauge located at the top of the unit is clearly visible and protected by the shroud handle

Reliable, Quality Product

- Tested and meets all known tests for MRI-compatible components used in conjunction with a magnetic resonance imager for Level 3 Tesla requirements
- Flow rate accuracy within $\pm 10\%$ of dial setting
- Regulator adjustment knob with positive flow detents guards against inadvertent flow setting changes
- Inspection windows in the shroud permit convenient leak inspection
- All units are 100% helium leak tested
- Each unit is assigned a unique serial number for positive identification and tracking
- Fill and evacuation rates are equivalent to standard post medical valves and deliver substantial time and money savings on the fill line
- Shroud is made of a durable, high-performance nylon ABS polymer blend and exhibits excellent chemical and UV resistance
- Cleaned for oxygen service and oil free per ASTM G-93

Variety of Configurations

- Available in both Check Valve and Shut-Off Valve configurations
- DISS outlet connections are available in all configurations
- Available in Standard Flow for hospital and pediatric applications, and High Flow for EMS/EMR applications

Design Specifications		
	English	Metric
Fill Connection	CGA 540	
Outlet Connection	Barbed Fitting for 1/4" I.D. Hose	
PRD Torque	50–65 in.-lbs.	5.6–7.3 N-m
Barbed Fitting Torque	15–20 in.-lbs.	1.7–2.2 N-m
Bonnet Torque	13–15 ft.-lbs.	17.6–20.3 N-m
Orifice Assembly Torque	25–35 in.-lbs.	2.8–4 N-m

Flow Ranges			
Model	Flow Range	Flow Adjustments	Applications
Standard Flow	0–15 LPM	0, 1/4, 1/2, 1, 2, 3, 4, 6, 8, 10, 12, 15 LPM	Hospital/Pediatrics
High Flow	0–25 LPM	0, 1/4, 1/2, 1, 2, 3, 4, 6, 8, 10, 15, 25 LPM	EMS/EMR

OxyGen I Series

Oxygen Valves with Integrated Pressure Regulators — Model V (Fill Shut-Off Valves)



V Model

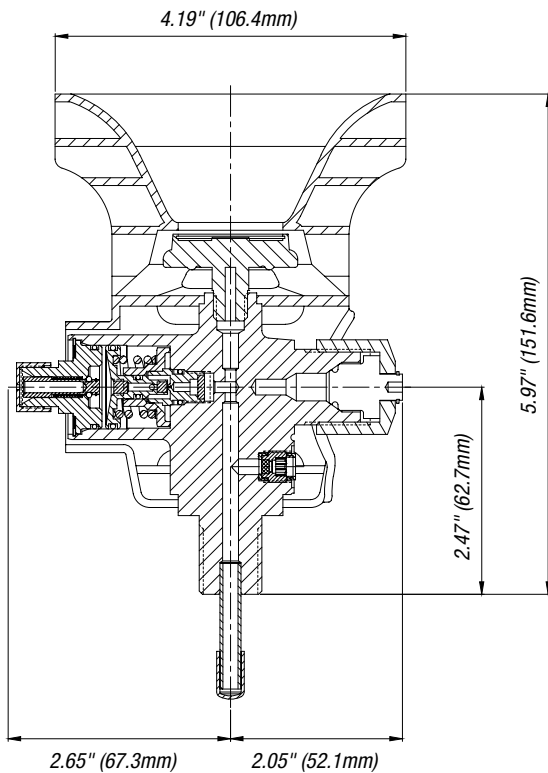

VRAM4TV-32-15D

Key Features & Benefits

- Flow control knob also acts as the principal shut-off device
- Single-control operational design is easy to use and therapist friendly
- Standard CGA 540 fill connection

Ordering Information Model V Version

Sherwood Part Number	DISS Connection	Flow Setting	Fill Connection	Inlet Connection
<i>OxyGen I Series Model V Fill Shut-Off Valves Unplated without Tube</i>				
VRM5V-32-75-15	—	0–15 LPM	CGA 540	¾"–16 UNF-2A Aluminum Cylinder
VRM5V-32-75-15D	✓	0–15 LPM	CGA 540	¾"–16 UNF-2A Aluminum Cylinder
VRM5V-32-75-25	—	0–25 LPM	CGA 540	¾"–16 UNF-2A Aluminum Cylinder
VRM5V-32-75-25D	✓	0–25 LPM	CGA 540	¾"–16 UNF-2A Aluminum Cylinder
<i>OxyGen I Series Model V Fill Shut-Off Valves Plated with Tube</i>				
VRAM5TV-32-75-15	—	0–15 LPM	CGA 540	¾"–16 UNF-2A Aluminum Cylinder
VRAM5TV-32-75-15D	✓	0–15 LPM	CGA 540	¾"–16 UNF-2A Aluminum Cylinder
VRAM5TV-32-75-25	—	0–25 LPM	CGA 540	¾"–16 UNF-2A Aluminum Cylinder
VRAM4TV-32-15	—	0–15 LPM	CGA 540	½" NGT Steel Cylinder
VRAM4TV-32-15D	✓	0–15 LPM	CGA 540	½" NGT Steel Cylinder
VRAM4TV-32-25	—	0–25 LPM	CGA 540	½" NGT Steel Cylinder

OxyGen I Series

Oxygen Valves with Integrated Pressure Regulators — Model VC (Master Shut-Off Valve)



VC Model

Key Features & Benefits

- Check valve design prevents pressure to the fill connection during therapy applications
- Master Shut-Off Valve isolates pressure from both the regulator and hose barb connection
- Protective shroud shields the Master Shut-Off Valve from unintended operation of the handwheel

Ordering Information Model VC Version

Sherwood Part Number	DISS Connection	Flow Setting	Fill Connection	Inlet Connection
<i>OxyGen I Series Model VC Master Shut-Off Valves</i>				
VRAM5TVC-32-75-15	—	0–15 LPM	CGA 540 Check Valve	¾"–16 UNF-2A Aluminum Cylinder
VRAM5TVC-32-75-15D	✓	0–15 LPM	CGA 540 Check Valve	¾"–16 UNF-2A Aluminum Cylinder
VRAM4TVC-32-15	—	0–15 LPM	CGA 540 Check Valve	½" NGT Steel Cylinder
VRAM4TVC-32-15D	✓	0–15 LPM	CGA 540 Check Valve	½" NGT Steel Cylinder

NOTE: 32 in Part Number = 2015 Working Pressure, 3360 PSI standard Pressure Relief Device (PRD). Use TL2051VC fill tool for Master Shut-Off Valve.

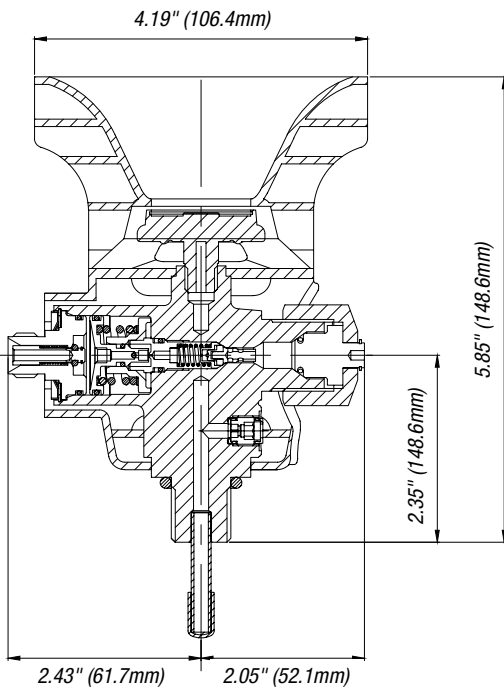

VRAM5TVC-32-75-15D



VC Model: Filling process requires a special 540 connection tool to override the back check mechanism (Part Number TL2051VC, shown here)

PLEASE NOTE: These components cannot be sold in Canada due to licensing restrictions. Potential customers outside the US should check licensing restrictions before considering purchase. These are fully approved for US distribution.

YVBA Series

Vertical Outlet Oxygen Valves



YVBA

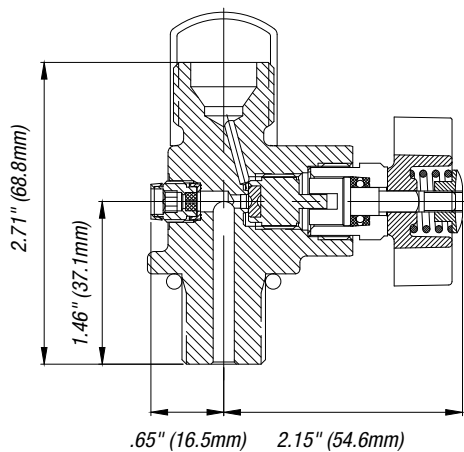

YVBA5454-XX-75G

Compact and designed for home healthcare use on small medical aluminum and composite cylinders.

Key Features & Benefits

- Compact design
- Chamber designed for easy operation
- Aluminum Silicon Bronze stem design for dependable service and long life
- Durable lower plug made of tough naval brass resists wear
- Lower plug is PTFE coated to add lubricity, which minimizes seizing and galling especially under high-pressure operation
- Internal bonnet gasket seal resists damage to chamber sealing area
- Compact molded Lexan® polycarbonate handwheel is easy to operate
- Single unit, compact Pressure Relief Device incorporates 165° F fusible metal backing to resist premature rupture and provide maximum cylinder protection
- Chrome plated for corrosion resistance and cosmetic appeal
- Cleaned for oxygen service and oil free per CGA G-4.1

For Product Markings Reference, see **F** on page 66.

Medical Valves

YVBA Series

Vertical Outlet Oxygen Valves

Design Specifications		
	English	Metric
Maximum Working Pressure	3000 PSI	207 Bar
Storage Temperature Range	-65° F → +155° F	-54° C → +68° C
Operating Temperature Range	-50° F → +120° F	-45° C → +49° C
Minimum Cycle Life	5000 Cycles	5000 Cycles
Operating Torque	3–5 in.-lbs.	.3–.6 N-m
Closing Torque	5–7 in.-lbs.	.6–.8 N-m
Bonnet Installation Torque	25–30 ft.-lbs.	33.9–7.3 N-m
Pressure Relief Device Installation Torque	50–65 in.-lbs.	5.6–7.3 N-m
Stem Nut Installation Torque	Nut Flush with Top of Stem	

Materials of Construction		
Sherwood Part Number	Part Description	Materials of Construction
N/A	Body	Brass C37700 Chrome Plated
1-3606-14	Bonnet	Brass, UNS ASTMB-16-53 Chrome Plated
3506-10	Gasket	Copper
1389-2D	Handwheel	Lexan®
	Plug and Seat Assembly	
3506-9	Plug	Aluminum Silicon Bronze C34200
	Seat	Nylon, Zytel 101 or Celanese 1000-11
3506-18	Packing	Viton®
3506-7	Packing	PTFE
9-3011A-2	Panel Mount Nut (as required)	Brass C36000, Chrome Plated
19-3506-11	Spring	Type 302 Stainless Steel, Passivated
9-3506-12	Stem	Aluminum Silicon Bronze Alloy #708-8 Nickel Plated
1-3506-8	Stem Nut	Brass C36000

Standards Conformance	
CGA V-9	Standard for Gas Cylinder Valves
CGA S1.1	Standard for Pressure Relief Devices
CGA V-1	Compressed Gas Cylinder Valve Outlet and Inlet Specifications
A-A-59860	U.S. General Services Administration Standards for Gas Cylinder Valves

YVBA Series

Vertical Outlet Oxygen Valves

Inlet O-Ring for Straight Threaded YVB Valves		
Sherwood Part Number	Size	Material
G016B	.625 UNF	Buna-N
G016T		PTFE
G210A9	.750 UNF	Buna-N
G210T		PTFE
G210J	.750 UNF	Viton®

Ordering Information				
Sherwood Part Number	CGA Outlet	Outlet Thread Size	Inlet Thread Size	Gauge
YVBA5454-XX-62	540	.903-14 NGO RH Ext.	.625-18 UNF-2A	None
YVBA5454-XX-62G	540	.903-14 NGO RH Ext.	.625-18 UNF-2A	1/8" NPTF
YVBA5454-XX-75	540	.903-14 NGO RH Ext.	.750-16 UNF-2A	None
YVBA5454-XX-75G	540	.903-14 NGO RH Ext.	.750-16 UNF-2A	1/8" NPTF

All valves supplied with CG-4 165° F fusible metal backed, flush-style Pressure Relief Devices and nickel rupture discs.

XX denotes Pressure Relief Device burst disc rupture pressure.

Valves are available in -28 (3000 Max. PSI), -32 (3360 Max. PSI) and -48 (5000 Max. PSI).

Special features available:

- CG-1 Pressure Relief Devices without fusible metal
- Hex-style, exhaust-equalizing Pressure Relief Device plugs
- .750-16 UNF inlets with O-ring glands in conformance with military specifications
- Round, barrel-style Lexan® handwheel

Key Replacement Parts	
Sherwood Part Number	Description
19-3506-11	Spring
3506-9	Lower Plug
6521S	Handwheel

Propane Cylinder Valves

PVE3250C Series

DOT Propane Cylinder Valves



PVE3250C-375

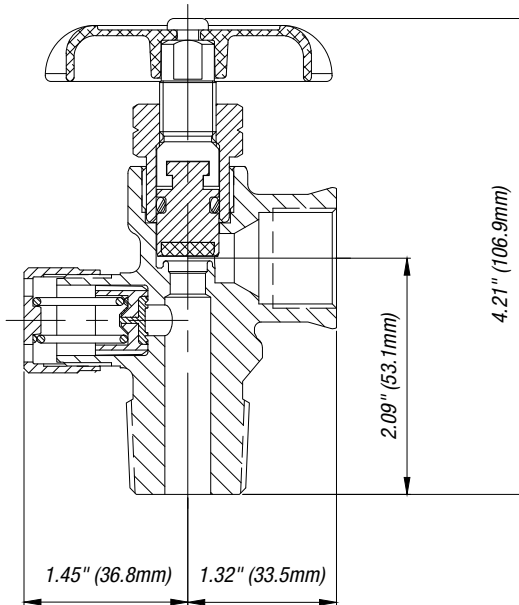

Key Features & Benefits

- Designed for cylinders up to 100 lb.
- Low-profile design to fit within all types of cylinder collars
- Robust internal seat design for improved cycle life and durability
- Ergonomic handwheel design for use in commercial and industrial applications
- Available with fixed level gauge
- Available with unique replaceable pressure relief valve for use in 240 and 260 PSI low pressure cylinders



PVE3250CLGXX.X

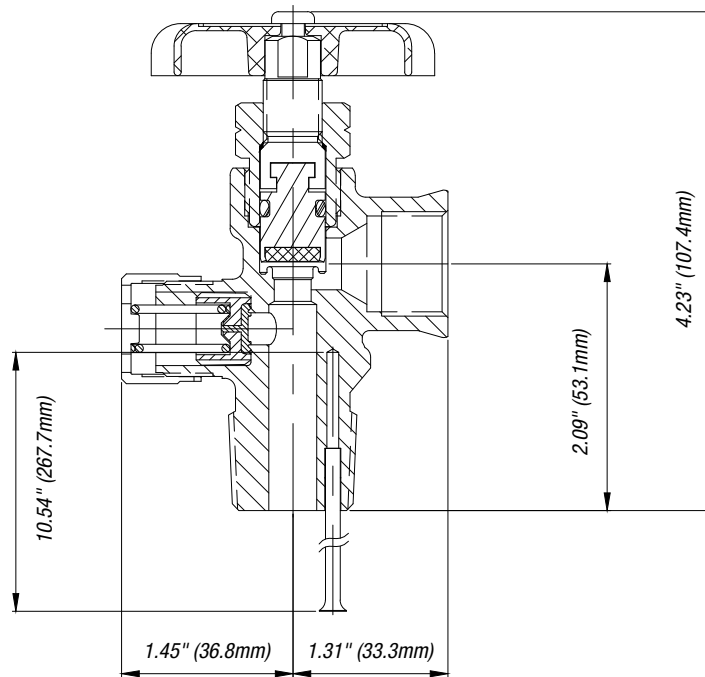

For Product Markings Reference, see **F** on page 66.

PVE3250C Series

DOT Propane Cylinder Valves

Materials of Construction		
Sherwood Part Number	PVE3250C-375	PVE3250CLGXX.X
Part Description	Materials of Construction	Materials of Construction
Body	Forged Brass C37700	Forged Brass C37700
Handwheel	SC84B Aluminum	SC84B Aluminum
Screw	Steel – Zinc Plated	Steel – Zinc Plated
Bonnet/Stem Subassembly		
Bonnet	Brass C36000	Brass C36000
Upper Stem	Brass C36000	Brass C36000
Lower Stem	Brass C36000	Brass C36000
Seat	Nylon Zytel 101L	Nylon Zytel 101L
O-Ring	Buna-N	Buna-N
Gasket	Nylon Zytel 101	Nylon Zytel 101
Safety Cap	Brass C36000	Brass C36000
Safety Spring	17-7 Stainless Steel	17-7 Stainless Steel
Poppet Assembly		
Holder	Nylon – Glass Filled	Nylon – Glass Filled
Seat	Buna-N	Buna-N
Thread Sealant	183 Everseal	183 Everseal
Adhesive	—	7680 Titan
Dip Tube	—	Brass C27200

Ordering Information						
Sherwood Part Number	Container Connection	Service Connection	Fixed Maximum Liquid Level Gauge	Start to Discharge Setting (PSI)	Audit Pressure	Special Features
PVE3250C-375	¾"–14 NGT	CGA 510	No	375–405 PSI	360–480 PSI	—
PVE3250CLGXX.X	¾"–14 NGT	CGA 510	Yes	375–405 PSI	360–480 PSI	Dip Tube 10.6 or 11.6

XX.X = Specify length of dip tube relative to cylinder size.

For Product Markings Reference, see **F** on page 66.



Propane Cylinder Valves

PVE12B Series

DOT Propane Forklift Valves — Fixed Maximum Liquid Level Gauge



PVE12B

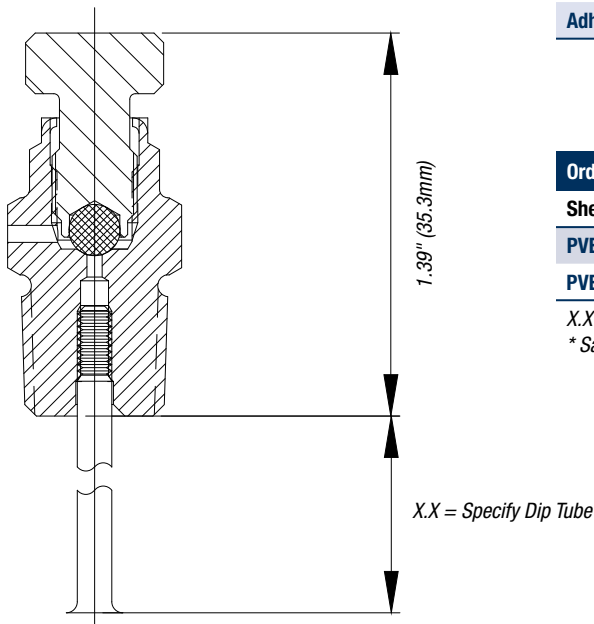

Key Features & Benefits

- Positive shut-off seal to ensure leak-tight performance
- Available with and without dip tube offering
- Equipped with #54 size orifice

Materials of Construction	
Part Description	Materials of Construction
Body	Brass C36000
Ball	Nylon, Zytel 101 6/6
Stem	Brass C36000
Dial	Polyethylene
Dip Tube	Brass C27200
Thread Sealant	183 Everseal
Adhesive	7680 Titan

Ordering Information	
Sherwood Part Number	Inlet Thread Size
PVE12B-X.X	1/4" NPT
PVE12BD-X.X*	1/4" NPT

X.X - Specify dip tube, furnished with 12" length unless otherwise specified
 * Same as PVE12B except includes "stop filling" dial

For Product Markings Reference, see **F** on page 66.



PVE1427B Series

DOT Propane Forklift Valves — Lift Truck 3/4" Service Valve Large Body



PVE1427B

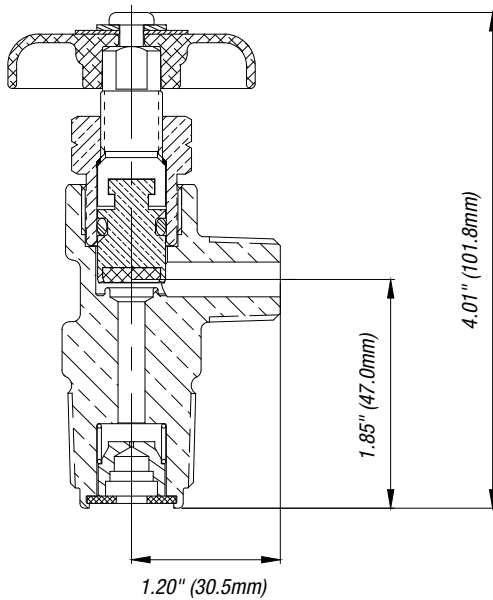

Key Features & Benefits

- Integral excess flow check valve that can fit all cylinder inlet configurations
- Special 1.7 GPM closing flow for lift truck and small engine applications
- Robust internal seat design for improved cycle life and durability
- Robust body with large bonnet design for heavy commercial use

Materials of Construction

Part Description	Materials of Construction
Body	Forged Brass C37700
Handwheel	SC84B Aluminum
Screw	Steel – Zinc Plated
Washer	Steel – Zinc Plated
Bonnet/Stem Subassembly	
Bonnet	Brass C36000
Upper Stem	Brass C36000
Lower Stem	Brass C36000
Seat	Nylon, Zytel 101
O-ring	Buna-N
Gasket	Nylon, Zytel 101
Decal Plate	Polyethylene
Spring	302 Stainless Steel
Poppet	Brass C36000
Washer	Steel – Zinc Plated
Thread Sealant	183 Everseal

Ordering Information

Sherwood Part Number	Size
PVE1427B	3/4"–14 NPT x 3/8" NPT

For Product Markings Reference, see **F** on page 66.

Propane Cylinder Valves

PVE1449 Series

DOT Propane Forklift Valves — Lift Truck 3/4" Service Valve Small Body



PVE1449

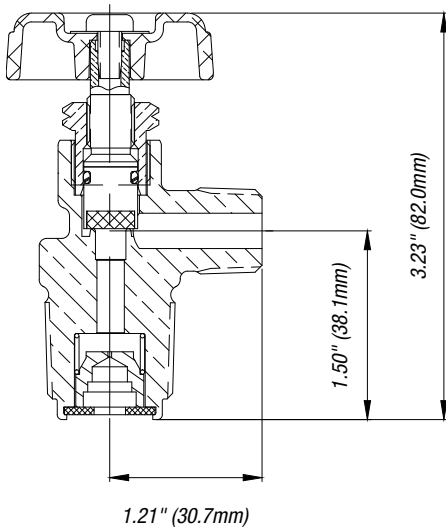

Key Features & Benefits

- Integral excess flow check valve that can fit all cylinder inlet configurations
- Special 1.7 GPM closing flow for lift truck and small engine applications
- Robust internal seat design for improved cycle life and durability
- Compact body design for light-duty commercial applications

Materials of Construction	
Part Description	Materials of Construction
Body	Forged Brass C37700
Handwheel	SC84B Aluminum
Screw	Steel – Zinc Plated
Bonnet/Stem Subassembly	
Bonnet	Brass C36000
Upper Stem	Brass C36000
Lower Stem	Brass C36000
Seat	Nylon 6/6
O-Ring	Buna-N
Decal Plate	Aluminum
Spring	302 Stainless Steel
Poppet	Brass C36000
Washer	Steel – Zinc Plated
Thread Sealant	183 Everseal

Ordering Information	
Sherwood Part Number	Size
PVE1449	3/4"–14 NPT x 3/8" NPT

For Product Markings Reference, see **F** on page 66.

PA1428 Series

DOT Propane Forklift Valves — Lift Truck Forklift Connectors for Installation on LPG Engine Fuel Lift Truck Systems



PA1428M

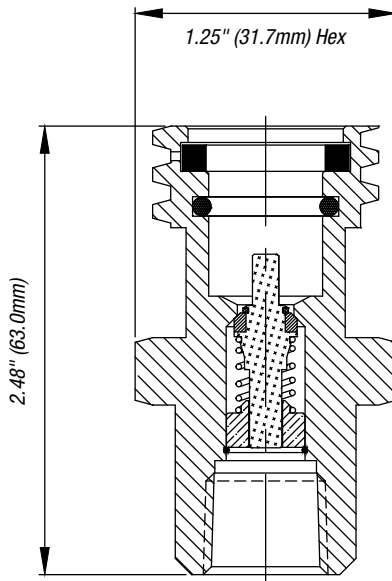

Key Features & Benefits

- Incorporates two seal mechanisms to ensure positive sealing during connection and filling process
- Replaceable tip for maximum service life
- Positive seal with little to no product loss at disconnect
- Multiple layers of security against possible leaks or misconnects

Materials of Construction	
Part Description	Materials of Construction
Body	Brass C36000
O-Ring	Buna-N
Poppet Assembly	
Poppet	Brass C36000
Poppet Seal	Buna-N
Washer	302 Stainless Steel
Guide	Brass C36000
Spring	Music Wire
Retaining Ring	SAE 1060 Steel, Black Phosphorus Coating
Seal Gasket	Buna-N



PA1428F

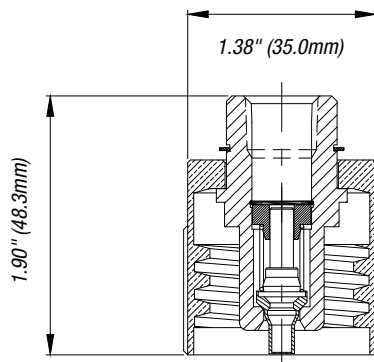

Ordering Information		
Sherwood Part Number	Description	Size
PA1428M	Male Connector	3/8"–18 NPT x 1 1/4–5 ACME
PA1428F	Female Connector	1/4"–18 NPT x 1 1/4–5 ACME

For Product Markings Reference, see **F** on page 66.

Propane Cylinder Valves

PVE435B

DOT Propane Forklift Valves — Full Internal Pressure Relief Valve



PVE435B

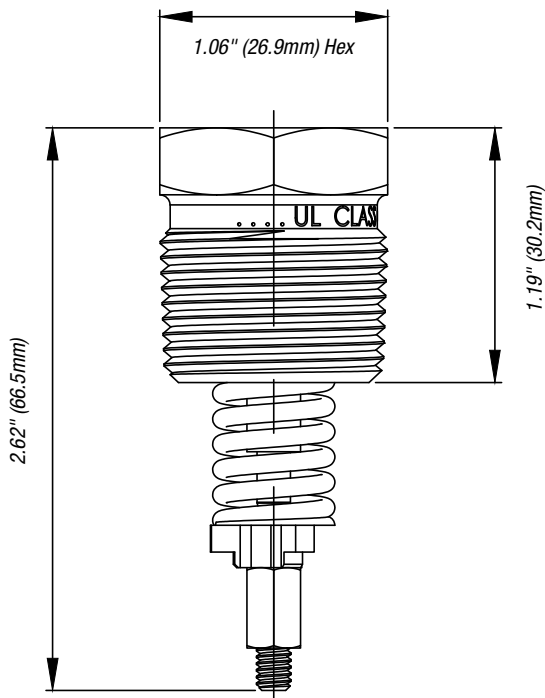

Key Features & Benefits

- Designed for use as primary relief device on forklift cylinders
- Robust seal design provides quick release of over pressure while minimizing product loss
- Two adapters and a protective cap are available as accessories to provide complete protection
- Non-adjustable, tamper-resistant design

Materials of Construction	
Part Description	Materials of Construction
Body	Brass C36000
Stem	302 Stainless Steel
Holder	Brass C36000
Seal	Viton®
Guide	Nylon – Glass Filled
Spring	17-7 Stainless Steel
Retainer	304 Stainless Steel
Nut	Brass C36000
Thread Sealant	183 Everseal

Ordering Information	
Sherwood Part Number	Size
PVE435B	3/4"-14 NPT

NOTE: NFPA Pamphlet #58 requires that: "All containers used in industrial truck (including forklift truck cylinders) service shall have the container pressure relief valve replaced by a new or unused valve within 12 years of the date of manufacture of the container and each 10 years thereafter."

For Product Markings Reference, see **F** on page 66.

NGV, NGVHM & NGRP Series

Global Industrial Gas Valves for Hydrocarbon-Based Flammable Gases

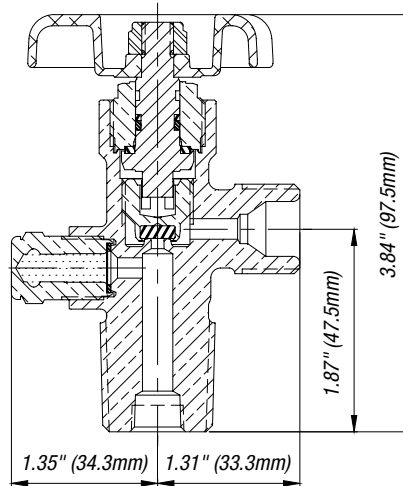

NGV Series
Up to 3000 PSI Working Pressure

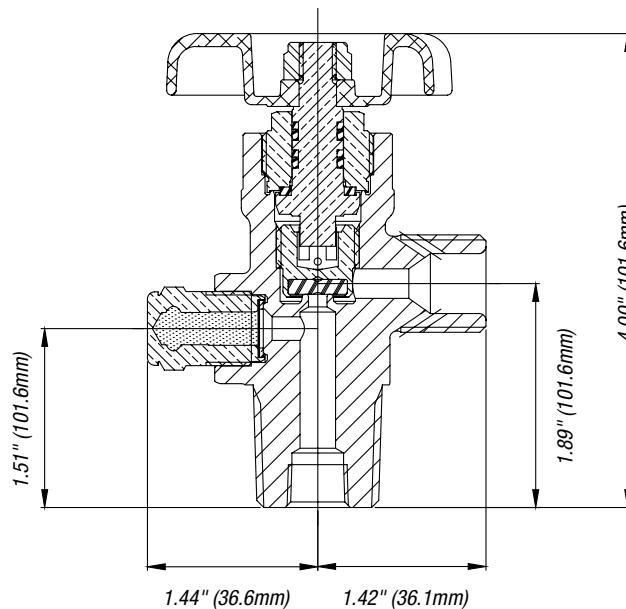

NGVHM
3001 PSI and Above Working Pressure

Global valve for hydrocarbon-based flammable gases, including compressed natural gas (CNG), methane, ethane and other similar gases.

Key Features & Benefits

- Automated assembly and testing processes ensure exceptional quality
- 100% helium leak tested
- Heavy-duty forged brass body for durability and high pressure
- Precisely machined internal components meet the most stringent international valve performance standards
- Reduced internal stress zones
- Innovative valve core design
- Durable Buna-N O-ring and PTFE backup O-ring compatible with flammable gases
- Pressure Relief Device (PRD) unitized plug design provides excellent flow characteristics
- Metal-to-metal seal below bonnet threads prevents pressure in the threads at top of valve body
- Direct-drive stem design with optimized O-ring (NGV) or double O-ring (NGVHM) seal reduces friction and operates at exceptionally low torque levels
- Available inlets include NGT, UNF, DIN477, BS, ABNT and others
- Tapped for dip tube as required

For Product Markings Reference, see **A** on page 66.

Alternative Energy Valves

NGV, NGVHM & NGRP Series

Global Industrial Gas Valves for Hydrocarbon-Based Flammable Gases

For further ordering information, refer to the Selection of Pressure Relief Devices on **page 62**, the Pressure Relief Device Numbering Matrix on **page 65**, the Product Markings Reference on **page 66** and the Valve Part Numbering Matrix on **page 70**.

Design Specifications		
	English	Metric
NGV Max. Working Pressure	3000 PSI	200 Bar
NGVHM Max. Working Pressure	6000 PSI	413 Bar
Burst Pressure	15,000 PSI	1034 Bar
Operating Temperature Range	-50° C → +130° F	-45° C → +54° C
Leak Rate Internal/External	1x10 ⁻³ atm cc/sec.	1x10 ⁻³ Bar mL/sec.
Minimum Cycle Life	2000 Cycles	
Cv Flow Factor	Standard: .690	
Operating Torque	NGV: 10–20 in.-lbs. NGVHM: 10–20 in.-lbs.	NGV: 1.1–2.2 N-m NGVHM: 1.1–2.2 N-m
Bonnet Assembly Torques	NGV: 50–60 ft.-lbs. NGVHM: 60–70 ft.-lbs.	NGV: 67.8–81.3 N-m NGVHM: 81.3–94.9 N-m
PRD Torques	NGV: 25–35 ft.-lbs. NGVHM: 40–50 ft.-lbs.	NGV: 33.9–47.4 N-m NGVHM: 54.2–67.8 N-m
NGRPV Cap Assembly Torques	15–25 ft.-lbs.	20.3–33.9 N-m

Materials of Construction		
Sherwood Part Number	Part Description	Materials of Construction
<i>NGV, NGVHM & NGRP Series Industrial and Chrome-Plated Valves</i>		
N/A	Body	Brass C37700; Chrome Plating When Applicable
1400-2 (NGV and NGRP) 1400-2A (NGVHM)	Bonnet	Brass C36000; Chrome Plating When Applicable
1919A	Handwheel	Aluminum A380
1251-6	Handwheel Nut	Steel Class 8, Zinc Plating
1400-4/1400-4A	Lower Plug	Brass C48500
1400-13/1400-13A	Lower Plug Seat	Nylon, Zytel 101
See Chart on Page 62	PRD	Plug: Brass C36000; Chrome Plating When Applicable Rupture Disc: Nickel Alloy 201; Copper C22000 Webbed Seal Gasket: Copper Dead Soft C11000
1400-3	Stem	Brass C36000
G011B-65	O-Ring	Buna-N
MS28774-011T	Back-up O-Ring	PTFE
1251-5	Thrust Washer	Delrin® 500 AF

Standards Conformance	
CGA V-9	Standard for Gas Cylinder Valves
CGA S1.1	Standard for Pressure Relief Devices
CGA V-1	Compressed Gas Cylinder Valve Outlet and Inlet Specifications
ISO 10297	International Standard for Cylinder Valves Design Specifications
ISO 11363-1	25E Inlet Thread Specifications
ISO 15996	International Standard for Residual Pressure Valves Design Specifications (NGRPV)
AS2473	Australian Standard for Compressed Gas Cylinder Valves
A-A-59860	US General Services Administration Standards for Gas Cylinder Valves

Key Replacement Parts	
Sherwood Part Number	Description
1400-31NGV-101KIT (NGV)	Bonnet & Seat Assembly Kit (includes 25 sub-assemblies)
1400-33NGV-101KIT (NGVHM)	
NGRPV-KIT	NGRPV Piston Assembly Kit (includes 50 sub-assemblies)

Lubricants	
Christo-Lube	Used in Valves for All Industrial Gas Applications

NGV, NGVHM & NGRP Industrial and Chrome-Plated Precision Valves

For further ordering information, refer to the Selection of Pressure Relief Devices on **page 62**, the Pressure Relief Device Numbering Matrix on **page 65**, the Product Markings Reference on **page 66** and the Valve Part Numbering Matrix on **page 70**.

NGV and NGVHM Series

Ordering Information				
Sherwood Part Number	Gas Service @ 70° F	CGA Outlet	Outlet Thread Size	Inlet Thread
<i>Methyl Fluoride</i>				
NGV35064-XX	0 PSI–3000 PSI	350	.825–14 NGO LH Ext.	¾"–14 NGT
<i>Ethane</i>				
NGV35061-XX	0 PSI–3000 PSI	350	.825–14 NGO LH Ext.	¾"–14 NGT
<i>Ethylene</i>				
NGV35061-XX	0 PSI–3000 PSI	350	.825–14 NGO LH Ext.	¾"–14 NGT
<i>Methane</i>				
NGV3504X-XX	0 PSI–3000 PSI	350	.825–14 NGO LH Ext.	½"–14 NGT
NGV3506X-XX	0 PSI–3000 PSI	350	.825–14 NGO LH Ext.	¾"–14 NGT
NGV3505X-XX	0 PSI–3000 PSI	350	.825–14 NGO LH Ext.	1½"–12 UNF
NGV35025EX-XX	0 PSI–3000 PSI	350	.825–14 NGO LH Ext.	25E ISO
NGV3508X-XX	0 PSI–3000 PSI	350	.825–14 NGO LH Ext.	1"–11½ NGT
NGVHM6956X-XX	3001 PSI–4700 PSI	695	1.045–14 NGO LH Int.	¾"–14 NGT
NGVHM6955X-XX	3001 PSI–4700 PSI	695	1.045–14 NGO LH Int.	1½"–12 UNF
NGVHM69525EX-XX	3001 PSI–4700 PSI	695	1.045–14 NGO LH Int.	25E ISO
NGVHM7036X-XX	4701 PSI–6400 PSI	703	1.125–14 NGO LH Int.	¾"–14 NGT
NGVHM70325EX-XX	4701 PSI–6400 PSI	703	1.125–14 NGO LH Int.	25E ISO
<i>Natural Gas</i>				
NGV3504X-XX	0 PSI–3000 PSI	350	.825–14 NGO LH Ext.	½"–14 NGT
NGV3506X-XX	0 PSI–3000 PSI	350	.825–14 NGO LH Ext.	¾"–14 NGT
NGV3505X-XX	0 PSI–3000 PSI	350	.825–14 NGO LH Ext.	1½"–12 UNF
NGV35025EX-XX	0 PSI–3000 PSI	350	.825–14 NGO LH Ext.	25E ISO
NGV3508X-XX	0 PSI–3000 PSI	350	.825–14 NGO LH Ext.	1"–11½ NGT
NGVHM6956X-XX	3001 PSI–4700 PSI	695	1.045–14 NGO LH Int.	¾"–14 NGT
NGVHM6955X-XX	3001 PSI–4700 PSI	695	1.045–14 NGO LH Int.	1½"–12 UNF
NGVHM69525EX-XX	3001 PSI–4700 PSI	695	1.045–14 NGO LH Int.	25E ISO
NGVHM7036X-XX	4701 PSI–6400 PSI	703	1.125–14 NGO LH Int.	¾"–14 NGT
NGVHM70325EX-XX	4701 PSI–6400 PSI	703	1.125–14 NGO LH Int.	25E ISO

NGRPV Series

Ordering Information				
Sherwood Part Number	Gas Service @ 70° F	CGA Outlet	Outlet Thread Size	Inlet Thread
<i>Methyl Fluoride</i>				
NGRPV35064-XX	0 PSI–3000 PSI	350	.825–14 NGO LH Ext.	¾"–14 NGT
<i>Ethane</i>				
NGRPV35061-XX	0 PSI–3000 PSI	350	.825–14 NGO LH Ext.	¾"–14 NGT
<i>Ethylene</i>				
NGRPV35061-XX	0 PSI–3000 PSI	350	.825–14 NGO LH Ext.	¾"–14 NGT
<i>Methane</i>				
NGRPV35045X-XX	0 PSI–3000 PSI	350	.825–14 NGO LH Ext.	½"–14 NGT
NGRPV3506X-XX	0 PSI–3000 PSI	350	.825–14 NGO LH Ext.	¾"–14 NGT
NGRPV35025EX-XX	0 PSI–3000 PSI	350	.825–14 NGO LH Ext.	25E ISO
<i>Natural Gas</i>				
NGRPV3504X-XX	0 PSI–3000 PSI	350	.825–14 NGO LH Ext.	½"–14 NGT
NGRPV3506X-XX	0 PSI–3000 PSI	350	.825–14 NGO LH Ext.	¾"–14 NGT
NGRPV35025EX-XX	0 PSI–3000 PSI	350	.825–14 NGO LH Ext.	25E ISO

X-XX in Part Number = safety type (X-) and safety pressure (-XX).

For example, NGV3504X-XX with a safety type of CG-5 and 4000 PSI safety pressure would be NGV35045-38.



Alternative Energy Valves

NBV Series
CNG Ball Valves

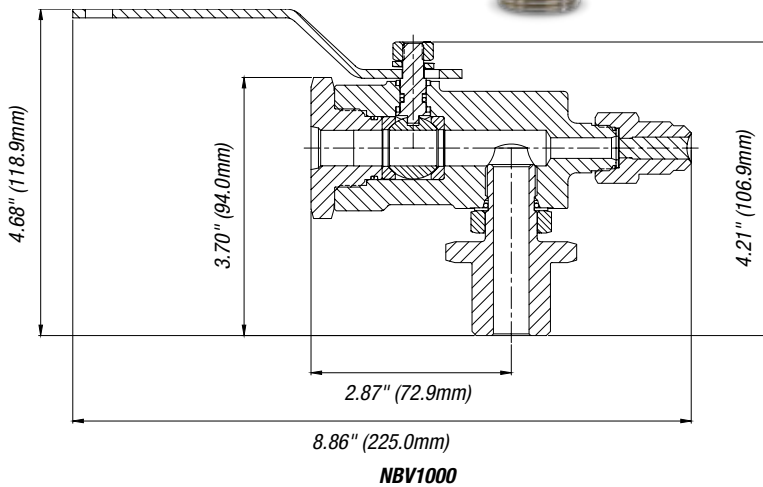

Materials of Construction	
Part Description	Materials of Construction
Handle	304 Stainless Steel
Nut	304 Stainless Steel
Lock Washer	316 Stainless Steel
Stem	316 Stainless Steel
Bonnet	Brass C36000
O-Ring – Bonnet	Buna-N
Backup Ring – Stem	PTFE
O-Ring – Stem	Buna-N
Stem Washers	Delrin® AF
Ball Seals	Tecaform 13 HPV
Safety (Optional)	
Safety Plug	Brass C36000
Safety Disc	Nickel
Safety Washer	C11000 Copper
Safety Fuse Metal	165° or 212° Eutectic Alloy
Fitting Subassembly	
Fitting	316 Stainless Steel
Nut	316 Stainless Steel
Washer	316 Stainless Steel
O-Ring – Fitting	Buna-N
Ball	316 Stainless Steel
Body	Brass C37000

Key Features & Benefits

- Designed for Type III and Type IV CNG (compressed natural gas) cylinders used in bulk gas cylinder storage stacks, gas vehicle cylinder stacks and fast-fill cylinder stacks
- Full-flow quarter-turn ball valve for fast filling with minimal cylinder neck valve constriction
- Saves commissioning time and reduces joint inspections
- Stem designed so that it cannot be blown out

Design Specifications		
	English	Metric
Max. Working Pressure	3675 PSI	253 Bar
Burst Pressure	15,000 PSI	1034 Bar
Operating Temperature Range	-20° F → +140° F	-29° C → +60° C
Leak Rate	1x10 ⁻⁴ atm cc/sec.	
Cv 90° Fitting	4.99 at 100 PSI 22.48 at 500 PSI	4.99 at 7 Bar 22.48 at 34 Bar
Operating Torque	40 in.-lbs.	4.5 N-m
Body	Brass, Nickel Plated	
Ball Seal	Delrin®	
O-Rings	Buna-N	
Bonnet Torque	45–55 ft.-lbs.	61–74.5 N-m
PRD Torque	30–40 ft.-lbs.	40.7–54.2 N-m
Handwheel Nut Torque	30–40 in.-lbs.	2.8–5 N-m
Jam Nut Torque on Fitting	47–57 ft.-lbs.	64.8–77.2 N-m

Ordering Information			
Sherwood Part Number	Inlet	Outlet	Safety
NBV1000	1½"-12 UNF	¾"-18 UNF2B	CG-5
NBV1000A	1½"-12 UNF	¾"-18 UNF2B	No PRD
NBV1001	¾"-14 NGT	¾"-18 UNF2B	No PRD
NBV1002	½"-14 NGT	¾"-18 UNF2B	No PRD
NBV1003	¾"-14 NGT	¾"-18 UNF2B	No PRD

NOTE: Additional inlets and outlets available.

For Product Markings Reference, see **E** on page 66.

PVE3250 Series

Propylene Valves for DOT Cylinders

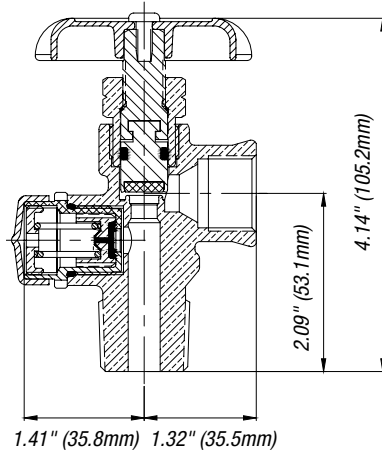

PVE3250R-435

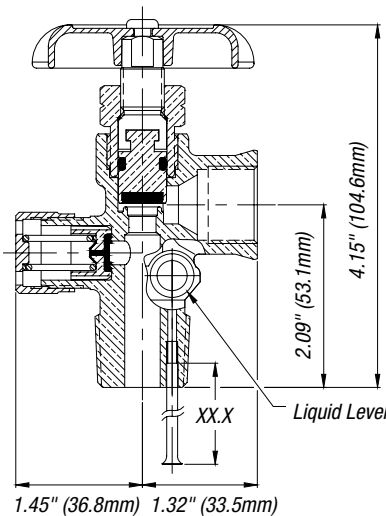

PVE3250CLG435

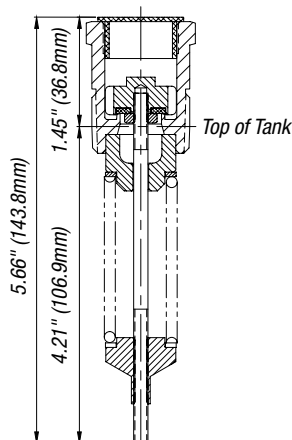

PVE446B

Designed for applications in production welding and cutting and supplying of fuel gases.

Key Features & Benefits

- Internal pressure relief valve
- Designed for 420 lb. DOT cylinder
- PVE3250R-435 and PVE3250CLG435 are compatible with both 4BW240 and 4BW260 cylinders
- Start to discharge pressure 435 PSI
- Compliant with CGA Technical Bulletin 27
- Rugged C36600 brass body construction
- Pressure Relief Device (CGA S-1.1 recommends replacing every 10 years)

Special Features for PVE3250R

- Compatible with both propane and propylene, 4BW240 and 4BW260 cylinders
- Includes replaceable PRV (CGA recommends replacing every 10 years)
- Tamper-resistant bonnet

Special Features for PVE446B

- Compatible with propylene only, 4BW260 cylinders
- Start to discharge pressure 435 PSI

Materials of Construction for PVE3250 Valves

Sherwood Part Number	Part Description	Materials of Construction
N/A	Body	Brass C37700
3250-8LH	Bonnet & Stem Assembly	
	Bonnet	Brass C36000
	Upper Stem	PTFE Coated Brass C36000
	O-Ring	Buna-N
	Lubricant	Drakeol #9 Oil
	Lower Stem	Brass C36000
1901	Seat	Nylon
	Handwheel	Aluminum
	Handwheel Screw	Plated Steel
3250R-10	Safety Assembly	
	Safety Body	Brass C36000
	Spring	Stainless Steel
	Safety Seat Holder	Glass Filled Nylon
	Safety Seat	Buna-N
N/A	Safety Retainer	Brass C36000
	Bonnet Locking Pin	Plated Hardened Steel
3250R-19	Protective Cap	Vinyl
N/A	Thread Sealant	Everseal 183

For Product Markings Reference, see **F** on page 66.

Alternative Energy Valves

PVE3250 Series

Propylene Valves

Ordering Information					
Sherwood Part Number	Cylinder Type	CGA Outlet Connection	Inlet Connection	Start to Discharge Setting (PSI)	Special Features
PVE3250C-435	4B260, 4BA260, 4BW260	510	3/4"-14 NGT	435-520	—
PVE3250CLG435-XX.X*	4B260, 4BA260, 4BW260	510	3/4"-14 NGT	435-520	Liquid Level Gauge, Dip Tube
PVE3250R-435	4B260, 4BA260, 4BW260, 4BW240	510	3/4"-14 NGT	435-480	Replaceable CG-7 Pressure Relief Device
PVE446B	4B260, 4BA260, 4BW260	1.000-20 UNEF-2B	1"-11.5 NPT	435-520	Relief Valve for Propylene Service Only

*XX.X — Specify length of dip tube relative to cylinder size.

Key Replacement Parts	
3250-8LH-KIT	Bonnet Assembly Kit for PVE3250C and PVE3250CLG
3250R-10-KIT	50 Replaceable Pressure Relief Devices for PVE3250R-435
TL3250R	Tool for Replaceable CG-7



TL3250R

DF Series

Alternative Fuel Valves

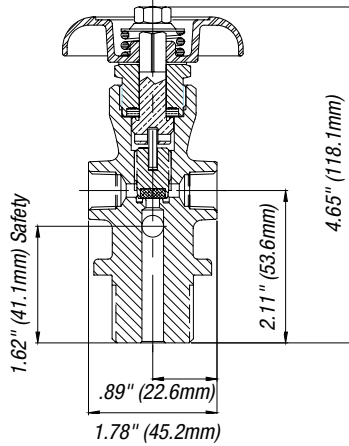

DFN11650-XX

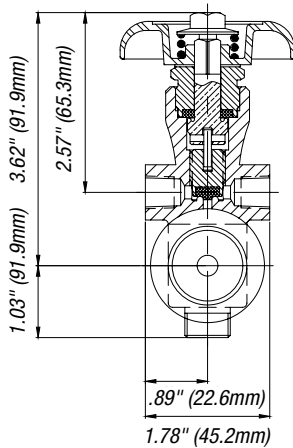

DFN1550-XX

Key Features & Benefits

- Dual outlet valves for fuel gas manifold use
- Dual outlet design allows for manifolding without use of adapters or tees, eliminating multiple joints
- Location of outlets above valve seat enables individual cylinder isolation without shutting off manifold
- Designed for direct manifold connections, reducing components and leak points
- Crimped seat feature prevents seat extrusion and cold flow of the polymer seat
- Available in multiple seat material configurations to accommodate all high-purity gas applications
- Increased flow (Cv) to aid in reducing vent and purge times
- Low operating torque design to ensure ease of operation during filling and use
- Available with unitized Pressure Relief Device having fuse-metal backed or unbacked burst disc
- Available with standard CGA connections as well as international inlets and outlets

Design Specifications

	English	Metric
Maximum Working Pressure	6250 PSI	431 Bar
Burst Pressure	20,000 PSI	1379 Bar
Storage Temperature Range	-65° F → +155° F	-54° C → +68° C
Operating Temperature Range	-50° F → +120° F	-46° C → +49° C
Minimum Cycle Life	5000 Cycles	
Operating Torque	15–25 in.-lbs.	1.7–2.8 N-m
Closing Torque	25–35 in.-lbs.	2.8–3.9 N-m
Bonnet Installation Torque	45–55 ft.-lbs.	61–74.5 N-m
Pressure Relief Device Installation Torque	30–40 ft.-lbs.	40.7–54 N-m
Stem Nut Installation Torque	Nut Flush with Top of Stem	

Alternative Energy Valves

DF Series

Alternative Fuel Valves

Materials of Construction		
Sherwood Part Number	Part Description	Materials of Construction
N/A	Body	Brass C37700
1250-2	Bonnet	Brass C36000
1401	Handwheel	Aluminum per ASTM SC84B
47-1003	Handwheel Nut	ANSI 1010 Steel, Plated with Organic Zinc Chromate
	Washer	Polypropylene
1250-40KV	Plug & Seat Assembly	
	Plug	PTFE Coated Brass C48500
	Seat	PCTFE
1250-6	Packing	PTFE
650-19SBF9-XX	Pressure Relief Device Assembly	
	Body	Brass C36000 (212° F or 165° F for backed devices)
	Disc	Nickel Alloy 201
45-1012	Gasket	Copper, Dead Soft
	Spring	Zinc Plated, Steel Spring Wire, Hard Drawn
1250-30	Stem & Tang Assembly	
	Tang	Type 303 or 304 Stainless Steel, Passivated
	Stem	Brass C36000
	Pin	Type 18-8 or 302 Stainless Steel, Passivated

Standards Conformance	
CGA V-9	Standard for Gas Cylinder Valves
CGA S-1.1	Standard for Pressure Relief Devices
CGA V-1	Compressed Gas Cylinder Valve Outlet and Inlet Connections
A-A-59860	U.S. General Services Administration Standards for Gas Cylinder Valves

Inlet O-Ring for Straight Threaded DF Valves		
Sherwood Part Number	Material	Size
G216B	Buna-N 70 Durometer	1.125 UNF

For further ordering information, refer to the Valve Part Numbering Matrix on page 71.

Ordering Information					
Sherwood Part Number	Gas Service	Number of Outlets	Outlet Orientation	Outlet Thread Size	Inlet Thread Size
DF11551-XXHFKF DF11651-XXFKF	Air/Oxygen, Inert Gas	Two 180° Apart	Horizontal Vertical	¼"–18 NPT Female	1.125 UNF-2A Straight
DF11561-XXHFKF DF11661-XXFKF	Air/Oxygen, Inert Gas	Two 180° Apart	Horizontal Vertical	¼"–18 NPT Female	¾"–14 NGT Tapered
DFN11555-XXHFKF DF11655-XXFKF	CNG/Hydrogen, Methane	Two 180° Apart	Horizontal Vertical	¼"–18 NPT Female	1.125 UNF-2A Straight
DF11565-XXHFKF DF11665-XXFKF	CNG/Hydrogen, Methane	Two 180° Apart	Horizontal Vertical	¼"–18 NPT Female	¾"–14 NGT Tapered
DFN16550-XXHFKP	Air/Oxygen, Inert Gas, CNG/Hydrogen, Methane	Two 180° Apart	Horizontal	.4375–20 UNF-2B Straight	1.125 UNF-2A Straight
DFN11550-XXHFKP	Air/Oxygen, Inert Gas, CNG/Hydrogen, Methane	Two 180° Apart	Horizontal	¼"–18 NPT Female	1.125 UNF-2A Straight
DFN11650-XXXKP	Air/Oxygen, Inert Gas, CNG/Hydrogen, Methane	Two 180° Apart	Vertical	¼"–18 NPT Female	1.125 UNF-2A Straight

PLEASE NOTE: Part numbers beginning with "DFN" represent Electroless Nickel Plated valves.

For Product Markings Reference, see **F** on page 66.



YVA Series High-Pressure Line Valves

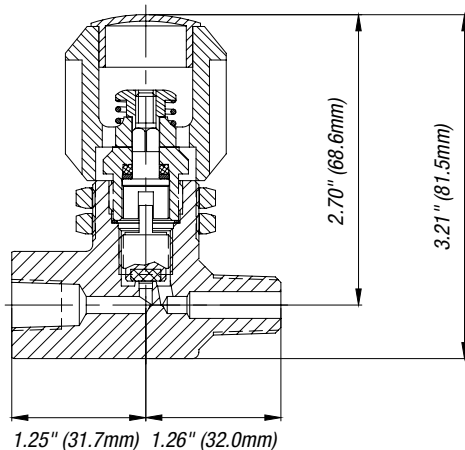

Designed for Compressed Gas Storage & Cascade Fill Systems meeting the demands of SCUBA & SCBA professionals internationally. The most state-of-the-art and efficient valve in the industry.

Key Features & Benefits

- Strong, durable forged brass body manufactured by Sherwood to specifications stricter than most commercial forging specifications
- Compact design especially suited for use on compressor or cascade panels
- Chamber specially designed for low-torque operation
- Aluminum Silicon Bronze stem design for dependable service and long life
- Proprietary dual packing chamber design provides dependable seal characteristics, long service life and easy operation
- Durable lower plug made of tough naval brass to resist wear
- Lower plug is PTFE coated to add lubricity, which minimizes seizing and galling especially under high-pressure operation
- Internal protected bonnet gasket seal provides positive, damage-resistant chamber seal
- Compact molded Lexan® polycarbonate handwheel is easy to use
- Safe, dependable and easily rebuilt and maintained

Design Specifications

	English	Metric
Maximum Working Pressure	6000 PSI	414 Bar
Storage Temperature Range	-65° F → +155° F	-54° C → +68° C
Operating Temperature Range	-50° F → +120° F	-45° C → +49° C
Minimum Cycle Life	5000 Cycles	5000 Cycles
Operating Torque	10–15 in.-lbs.	1.1–2.2 N-m
Closing Torque	10–15 in.-lbs.	1.1–2.2 N-m
Bonnet Installation Torque	25–30 ft.-lbs.	2.8–3.4 N-m
Stem Nut Installation Torque	Nut Flush with Top of Stem	

For Product Markings Reference, see **F** on page 66.

Specialty Applications

YVA Series

High-Pressure Line Valves

Materials of Construction	
Part Description	Materials of Construction
Body	Brass C37700 Chrome Plated
Bonnet	Brass, UNS ASTMB-16-53 Chrome Plated
Gasket	Copper
Handwheel	Lexan®
Handwheel Cap	Lexan®
Lower Plug	Aluminum Silicon Bronze C64200
Lower Plug Seat	Nylon: Zytel 101 or Celanese 1000-11
Packing (3506-18)	Viton®
Packing (3506-7)	PTFE
Panel Mount Nut (as required)	Brass C36000, Chrome Plated
Spring	Type 302 Stainless Steel, Passivated
Stem	Aluminum Silicon Bronze Alloy #708-8 Nickel Plated
Stem Nut	Brass C36000

Standards Conformance	
CGA V-9	Standard for Gas Cylinder Valves
A-A-59860	US General Services Administration Standards for Gas Cylinder Valves

Ordering Information					
Sherwood Part Number	Inlet Thread Size	Outlet Thread Size	Panel Mount	Panel Hole Size	Chrome Plated
YVA3010	¼"–18 NPT Int.	¼"–18 NGT Ext.	No	—	Yes
YVA3010A	¼"–18 NPT Int.	¼"–18 NGT Ext.	Yes	1¼"	Yes
YVA3010AB*	¼"–18 NPT Int.	¼"–18 NGT Ext.	Yes	1¼"	Yes

* Cleaned for Oxygen service

430 Series Master Shut-Off Valves

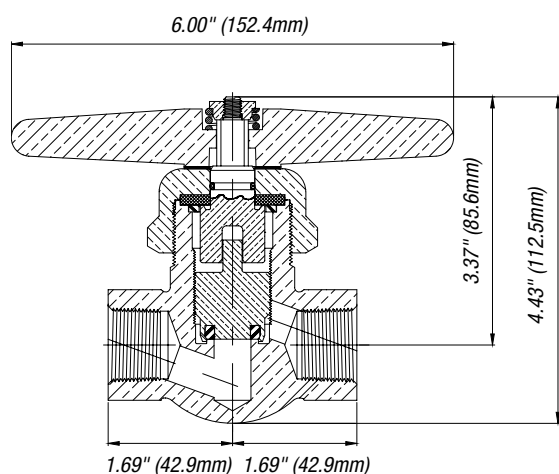

430CW-N

High-pressure shut-off valves designed for heavy-duty use on tube trailers, manifold systems and other piping systems. Valves are suitable for use with oxygen, acetylene, nitrogen, argon, helium, hydrogen, carbon dioxide, nitrous oxide and other inert gases.

Key Features & Benefits

- Safer — There is less chance of ignition from oxygen compression due to a toroidal seat insert that minimizes the area of fluoroplastic material subject to oxygen impact forces
- Heat-absorbing metal surfaces encapsulate all but the shut-off surface of the seat insert and serve as a heat sink to reduce the chance of ignition
- Longer life of downstream equipment reduces the forces against regulators and other auxiliary equipment due to the sudden surge of high-pressure gas when the valve is opened quickly
- Controlled flow — When the valve is opened quickly, dynamic forces directed against downstream equipment are reduced by a skirt on the lower stem shrouding the raised body seat, and this feature protects auxiliary equipment from sudden surges of high-pressure gas when valve is opened
- Full flow is achieved when handle is turned two full turns
- Forged brass body with copper alloy parts — 430C lower stem, C64200 aluminum-silicon-bronze not for acetylene; 430CX lower stem, C36000 free cutting brass for acetylene
- Pressure seal design with handwheel spring applies upward force against upper stem and packing to ensure stem seal even at low gas pressures, and this pressure seal bonnet design assures positive seal
- O-ring moisture seal on upper stem protects against environmental contamination and includes brass washer second seal restricting moisture intrusion, which is useful in cold (freezing) environments
- PCTFE seat insert and PTFE packing has been used successfully for over 30 years in master shut-off valve applications
- Large bar handle for ease of operation
- Pressure ratings — 6000 PSI, non-corrosive gases except oxygen; 5500 PSI at 120° F oxygen
- Aluminum silicon bronze lower stem provides extra-long life and durability during operation
- Inert PTFE packing provides leak-free stem seal, long cycle life and resistance to corrosion

Design Specifications

	English	Metric
Maximum Working Pressure	6000 PSI	413 Bar
Maximum Working Pressure, Oxygen	5500 PSI @ 120° F	379 Bar @ 49° C
Burst Pressure	15,000 PSI	1034 Bar
Leak Rate	1x10 ⁻³ atm cc/sec	1x10 ⁻³ Bar mL/sec
Operating Temperature	-50° F → +130° F	-45° C → +54° C
Cv Flow Factor	3.16	3.16

Specialty Applications

430 Series

Master Shut-Off Valves

Materials of Construction		Ordering Information				
Part Description	Materials of Construction	Sherwood Part Number	Outlet Thread Size	Inlet Thread Size	Seat Holder*	Pressure Ratings (see Notes A, B, C below)
Body	Forged Brass C37700	430CW-F	1"-11½ NPSM (Male)	1"-11½ NPSM (Male)	P430CX12-10	B
Packing	PTFE	430CW-M	½"-14 NPT (Female)	½"-14 NPT (Female)	P430CX12-10	B
Handwheel Washer	High Density Fiber	430CW-MS	½" Pipe Socket Weld	½" Pipe Socket Weld	P430CX12-10	B
Packing Nut	Brass C36000	430CW-N	¾"-14 NPT (Female)	¾"-14 NPT (Female)	P430CX12-10	B
Stem	Brass C36000	430CW-NS	¾" Pipe Socket Weld	¾" Pipe Socket Weld	P430CX12-10	B
Handle	Forged Brass C37000	430CWX1-F	1"-11½ NPSM (Male)	1"-11½ NPSM (Male)	P430CX1-10A	A
O-Ring	Neoprene	430CWX1-M	½"-14 NPT (Female)	½"-14 NPT (Female)	P430CX1-10A	A
Seat Assembly		430CWX1-MS	½" Pipe Socket Weld	½" Pipe Socket Weld	P430CX1-10A	A
Seat Holder	Aluminum Silicon Bronze C64200	430CWX1-N	¾"-14 NPT (Female)	¾"-14 NPT (Female)	P430CX1-10A	A
Seat Holder (430CX1 Series)	Brass C36000	430CWX1-NS	¾" Pipe Socket Weld	¾" Pipe Socket Weld	P430CX1-10A	A
Seat	PCTFE	430CWX9-FM	½"-14 NPT (Female)	1"-11½ NPSM (Male)	P430CX12-10	B
Spring Nut Plated	Brass C36000	430CWX10-F	1"-11½ NSPM, LH (Male)	1"-11½ NSPM, LH (Male)	P430CX12-10	B
Spring	302 Stainless Steel					
Lubricant	Fluorolube					
Washer	Brass C36000					

* P430CX12-10 (Aluminum Silicon Bronze) is not for use with acetylene or MAPP gases; P430CX1-10A (Brass) is for use with all non-corrosive, non-liquefied gases. To order brass washer replacement part, use part number P430CX13-20.

NOTES:

A. 6000 PSI @ 70° F except 5500 PSI @ 120° F for oxygen.

B. 6000 PSI valve is cleaned for oxygen service with oxygen pressure not exceeding 5500 PSI @ 120° F.

Replacement Parts Kits

P430C-32W

Contains one of each component listed below.

P430-13	Handwheel Gasket
P1200-7	Handwheel Nut
P1200-11	Handwheel Spring
P430CX13-20	Washer
P430CX12-21K (ASB)	Lower Stem and Seal Insert Assembly
P430B-27-13	Stem O-Ring
P430-6T	PTFE Packing

P430CX1-32W

Contains one of each component listed below.

P430-13	Handwheel Gasket
P1200-7	Handwheel Nut
P1200-11	Handwheel Spring
P430CX13-20	Washer
P430CX1-21AK (Brass)	Plug and Seat Assembly
P430B-27-13	Stem O-Ring
P430-6T	PTFE Packing

Kits

Sherwood Part Number	Description
P430CX1-32W	Includes the P430CX13-20
P430C-32W	Includes the P430CX13-20

Refrigerant Recovery Valves



RVE6660V
Vapor Service



RVE6660L
Liquid Service

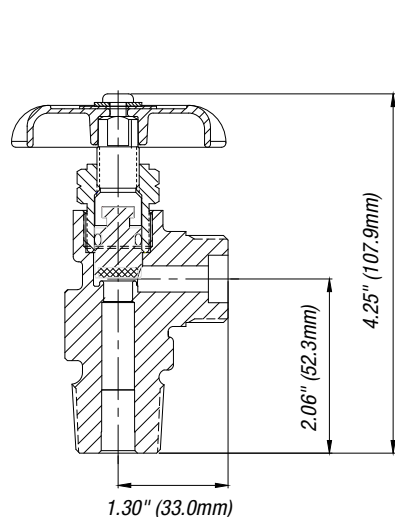

RVE6660V

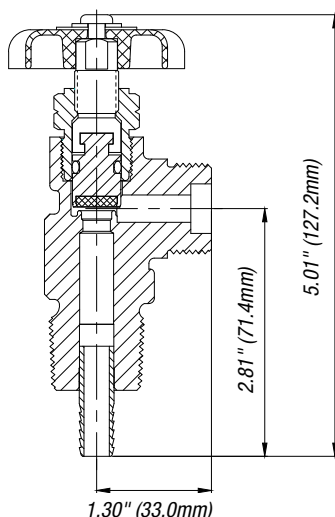

RVE6660L

Designed to assure the cleanest, driest refrigerant gas for the most efficient operation of any HVACR system. Meets the Clean Air Act of 1990 with the highest materials demands by the EPA.

Key Features & Benefits

- Replaceable bonnet and stem assembly
- PTFE coated anti-galling stem for ease of operation
- Replaceable color-coded handwheels
- Valves engineered and manufactured for durability and longevity, employing time-proven concepts, processes and methods
- Major component forged and machined from brass alloys controlled to exacting specifications of the Copper Development Association, Inc.

Materials of Construction		
Part Description	RVE6660L	RVE6660V
Body	Brass C37700	Brass C37700
Bonnet & Stem Sub		
Bonnet	Brass C36000	Brass C36000
Upper Stem	Brass C36000	Brass C36000
Gasket	Nylon 101	Nylon 101
Lower Stem Sub	O-Ring: Neoprene Lower Stem: Brass C36000 Seat: Nylon 101	O-Ring: Neoprene Lower Stem: Brass C36000 Seat: Nylon 101
Handwheel	ASTM SC848 Aluminum Die Cast	ASTM SC848 Aluminum Die Cast
Decal Plate	Polyethylene Low Density	Polyethylene Low Density
Washer	Steel w/Zinc Plate	Steel w/Zinc Plate
Screw	Steel w/Zinc Plate	Steel w/Zinc Plate
Tube	Brass C36000	—
Thread Sealant	Everseal 183	Everseal 183

Key Replacement Parts RVE6660V	
Sherwood Part Number	Description
3250-9LH-KIT	Bonnet & Stem Assembly
1901B	Vapor Handwheel (blue)
3250-9V	Decal Plate (vapor)
J23B19RA	Washer
J12-F10-85AP	Screw

Key Replacement Parts RVE6660L	
Sherwood Part Number	Description
3250-9LH-KIT	Bonnet & Stem Assembly
1901R	Liquid Handwheel (red)
3250-9L	Decal Plate (liquid)
J23B19RA	Washer
J12-F10-85AP	Screw

For Product Markings Reference, see **F** on page 66.



Specialty Applications

Refrigerant Recovery Valves



YVE445FR



YVE3865FR

YVE445FR Relief Valve

Key Features & Benefits

- For 1" NPT tank connection
- Up to 1000 lb. water capacity
- 260 PSI Working Pressure
- Start to discharge pressure: 390–520 PSI

YVE3865FR Relief Valve

Key Features & Benefits

- Relief valve for half-ton, portable refrigerant tanks
- Up to 1000 lb. water capacity containers
- Cylinder Working Pressure up to 260 PSI
- Used in conjunction with vapor and liquid recovery valve sets
- Safety set pressure: 500 PSI
- Start to discharge pressure: 490–520 PSI

Materials of Construction for YVE445FR Valves

Part Description	Materials of Construction
Body	Brass C36000
Stem & Poppet Sub	
Poppet	Brass C36000
Seat	Neoprene W
Nut	Steel w/Zinc Plating
Stem	Steel w/Zinc Plating
Thread Sealant	Titan 7271
Guide	Brass C36000
Washer	Brass C36000
Spring	302 Stainless Steel
Retainer	Brass C36000
Protective Closure	Polyethylene Low Density
Thread Sealant	Everseal 183

Materials of Construction for YVE3865FR Valves

Part Description	Materials of Construction
Body	Brass C36000
Poppet Assembly	
Poppet	Brass C36000
Seat	Neoprene W
Spring	302 Stainless Steel
Retainer	Brass C36000
Protective Closure	Polyethylene
Thread Sealant	Everseal 183

Ordering Information

Sherwood Part Number	Description	Tank Connection	CGA Outlet	Handwheel
RVE6660V	Vapor Service Valve	¾"–14 NGT	660	Blue to Indicate Vapor Service
RVE6660L	Liquid Service Valve	¾"–14 NGT	660	Red to Indicate Liquid Service
YVE445FR	Relief Valve	1" NPT	None	None
YVE3865FR	Relief Valve	¼"–18 NPT	None	None

For Product Markings Reference, see **F** on page 66.

Refrigerant Cylinder Valves



1014-B

1014 Valve Series

Key Features & Benefits

- Diaphragm refrigerant cylinder valve for use in refrigerant recovery applications
- Integral Pressure Relief Device (CG-7)
- Diaphragm construction with sulfur-free neoprene seat

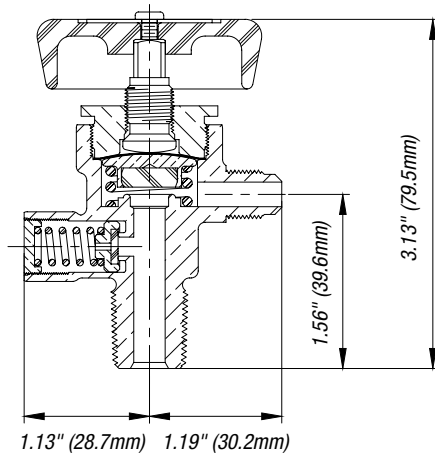

1014-B

Ordering Information

Sherwood Part Number	CGA	Outlet	Inlet	Safety	Extra Features
1014-B	165	1/4" SAE Flare	1/4"-18 NGT	400 PSI	—
1014-C	165	1/4" SAE Flare	3/8"-18 NGT	400 PSI	—
1014-CB	165	1/4" SAE Flare	3/8"-18 NGT	400 PSI	Cleaned For Oxygen Service and Oil Free Per CGA G-4.1
1014X2-B	165	1/4" SAE Flare	1/4"-18 NGT	600 PSI	Cleaned For Oxygen Service and Oil Free Per CGA G-4.1
1014X2-C	165	1/4" SAE Flare	3/8"-18 NGT	600 PSI	Cleaned For Oxygen Service and Oil Free Per CGA G-4.1

Specialty Applications

Refrigerant Cylinder Valves



1031X19-CL1

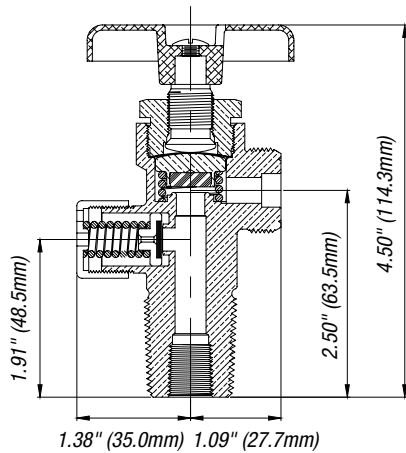

1031X19-CL1

1031X19-CL1

Diaphragm Packless Refrigerant Valve with 1/4 NPT Tapped Inlet and PCTFE Seat

Key Features & Benefits

- Cylinder valve for use with refrigerant gases
- Diaphragm construction with unique PCTFE seat
- Cylinder Working Pressure up to 250 PSI
- Pressure Relief Device (CG-7) start to discharge pressure: 450 PSI

Materials of Construction	
Part Description	Materials of Construction
Body	Brass C37700
Stem	Brass C36000
Screw	Steel w/Zinc Plating
Handwheel	Zamak #3 Zinc Die Cast
Bonnet	Brass C36000
Diaphragms	Brass C36000
Protective Closure	316 Stainless Steel
Seat Holder	Brass C36000
Seat	PCTFE
Spring	302 Stainless Steel
Safety Cap	Brass C36000
Safety Spring	Music Wire w/Zinc Plating
Safety Seat Holder	Brass C36000
Safety Seat	Neoprene W

Ordering Information					
Sherwood Part Number	CGA	Outlet	Inlet	Safety	Features
1031X19-CL1	660	1"–14 NGO RH Ext.	3/4"–14 NGT	450 PSI	1/4" Tapped Inlet, PCTFE Seat

For Product Markings Reference, see **D** on page 66.

3132 Pipe-a-Way Fuse Plugs

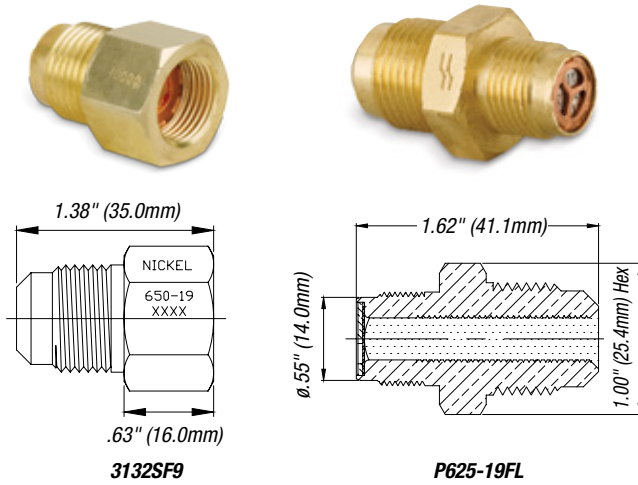

Key Features & Benefits

- 3132: Vented Pressure Relief Valve Assemblies for use in conjunction with 650 external-style relief devices
- P625-19N9-FL-XXW Series: Flared Pressure Relief Devices Assembly for use with 625 internal-style N-style relief devices
- Enable a pipe-a-way configuration
- Provide method of direction for flow or relief

Ordering Information

Sherwood Part Number	Outlet	Inlet	Fusible Metal	Material
3132SF9-XX Series	½" SAE Flared	.650-19	None	Nickel
3132SB9-XX Series	½" SAE Flared	.650-19	212° F	Copper
3132SM9-XX Series	½" SAE Flared	.650-19	165° F	Copper
3132SBF9-XX Series	½" SAE Flared	.650-19	212° F	Nickel
P625-19N9-FL-XXW Series	½" SAE Flared	.625-19	212° F	Nickel

Fuse Plugs

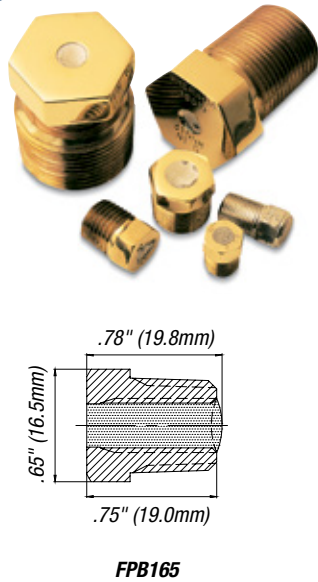

Key Features & Benefits

- All fuse plugs are UL® Listed
- Produced from high-quality brass
- Meticulously controlled fusible alloy ensures accurate and consistent melt temperatures
- Fusible alloy is cast into plug body to ensure an extremely strong bond between alloy and plug body
- Fusible plug stamped with fusible metal yield temperature

Ordering Information				
Sherwood Part Number	Thread Size	Body Material	Fusible Metal Yield Temp. Nominal	Clear Opening Diameter
FPA212	⅜"-27 NPTF	Brass	212° F	.219"
FPB165	¼"-18 NPT	Brass	165° F	.250"
FPB212	¼"-18 NPT	Brass	212° F	.250"
FP201B-NPT	⅜"-27 NPTF	Brass	212° F	.199"
FP201B-NPT-3	⅜"-27 NPTF + 3 Threads Oversize	Brass	212° F	.199"
FP202B-BSP	⅜" BSP	Brass	212° F	.199"

NOTE: BSP = British Standard Pipe Thread, NPT = National Pipe Thread, NPTF = National Pipe Threaded Fine.

Pressure Relief Devices

Pressure Relief Devices

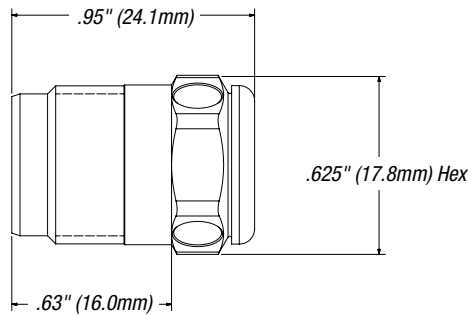

P625-19X9-XXX

Ordering Information

Pressure Relief Device			-XX	Cylinder Working Pressure			Disc Rupture Range PSI @ 160° F	
CG-1 Frangible Disc No Fuse Metal	CG-4 * Frangible Disc 165° F Fuse Metal	CG-5 * Frangible Disc 212° F Fuse Metal		D.O.T. Spec 3A 3AA 3AL Cylinders PSI	D.O.T. Exemption Cylinders PSI	International Cylinders Bar	Min.	Max.
<i>GV Low Pressure</i>								
P625-19N9-26	P625-19C9-26M	P625-19C9-26W	-26	1665	—	—	2500	2775
P625-19N9-28	P625-19C9-28M	P625-19C9-28W	-28	1800	—	—	2700	3000
P625-19N9-32	P625-19C9-32M	P625-19C9-32W	-32	2015	—	—	3025	3360
P625-19N9-35	P625-19C9-35M	P625-19C9-35W	-35	2265	—	—	3400	3775
P625-19N9-38	P625-19C9-38M	P625-19C9-38W	-38	2400	—	—	3600	4000
P625-19N9-39	P625-19C9-39M	P625-19C9-39W	-39	—	—	200	3915	4350
P625-19N9-43	P625-19C9-43M	P625-19C9-43W	-43	2670	—	—	4005	4450
P625-19N9-46	P625-19C9-46M	P625-19C9-46W	-46	2900	—	—	4350	4833
P625-19N9-47	P625-19C9-47M	P625-19C9-47W	-47	2950	—	—	4425	4917
<i>GVHM High Pressure</i>								
P625-19N9H-48	—	P625-19C9H-48W	-48	3000	—	230	4500	5000
P625-19N9H-55	—	P625-19C9H-55W	-55	3500/3600	—	—	5250	5833
P625-19N9H-63	—	P625-19C9H-63W	-63	4000	—	—	6000	6665
P625-19N9H-65	—	P625-19C9H-65W	-65	—	4500	300	6075	6750
P625-19N9H-71	—	P625-19C9H-71W	-71	—	5000	—	6750	7500
P625-19N9H-78	—	P625-19C9H-78W	-78	5000	—	—	7500	8333
P625-19N9H-85	—	P625-19C9H-85W	-85	—	6000	—	8100	9000
P625-19N9H-95	—	P625-19C9H-95W	-95	6000	—	—	9000	10,000

* Copper disc must be used for hydrogen service.

Pressure relief devices come standard with a copper disc. For nickel disc option with CG-4 and CG-5, use an "N" in place of the "C" in the part number.

For chrome-plated CG1 PRDs, add "1" before Part Number. For example, P625-19N9H-XX becomes 1-P625-19N9H-XX.

Pressure Relief Devices Technical Information

Almost all compressed gas containers are fitted with pressure relief devices. A pressure relief device is a pressure- and/or temperature-activated device used to prevent the pressure from rising above a predetermined maximum, and thereby prevent rupture of a normally charged cylinder when subjected to a standard fire test as required by Title 49 of the U.S. Code of Federal Regulations (49CFR 173.34(d)), or equivalent regulations of Transport Canada.

The Compressed Gas Association, in pamphlet CGA S-1.1, has classified pressure relief devices according to type using the letter designation CG followed by a numeral. Each of these types described are in the following subsections (reference CGA S-1.1).

Type CG-1 (Pressure Relief Rupture Disk)

A rupture disk (synonymous with the name burst disk within the industry) is a pressure-operated device which affords protection against development of excessive pressure in cylinders. This device is designed to sense excess pressure in a cylinder and will function when the cylinder is of sufficient magnitude to cause the rupture or bursting of the rupture disk element, thereby venting the contents of the cylinder. The rupturing of the rupture disk element results in a non-reclosing orifice.

Rupture disk devices installed on compressed gas cylinders may be either an integral part of the cylinder valve assembly or may be installed on the cylinder as an independent attachment. The materials of construction selected must be compatible with the fluid in the cylinder as well as the cylinder valve materials with which the rupture disk device comes in contact in order to minimize corrosion.

One of the most common types of rupture disk devices consists of a gasket and a rupture disk and a rupture disk holder. These components are only supplied as factory-assembled devices designed to be replaced as a unit.

The gasket is the part which provides the proper seal to prevent leakage of the cylinder contents past the rupture disk assembly and may be constructed of metallic or nonmetallic materials.

The rupture disk is the operating part of the pressure relief device and, when installed in a proper rupture disk holder, is designed to burst at a predetermined pressure to permit discharge of the cylinder contents. Such disks are usually made of metallic materials and may be of flat, preformed, reinforced, grooved or scored construction. Nonmetallic materials are also used for specific applications.

The rupture disk holder is the part of the pressure relief device which contains the opening, against which the rupture disk mates. The rupture disk holder usually also contains the discharge porting or passages, beyond the operating parts of the device, through which fluid must pass to reach the atmosphere. In many cases, the discharge holder is provided with radial vent holes through which the fluid in the cylinder vents to the atmosphere. This radical discharge design provides an anti-recoil feature, which minimizes rocketing of compressed gas cylinders during discharge of the contents through the pressure relief device. Other types of discharge ports may also be provided in rupture disk holders to suit specific application requirements.

Most rupture disk devices are designed with holders having either sharp-edged or radius-edged orifices to which the rupture disk mates. The sharp-edged orifice produces a shear-type actuation mode whereby the disk ruptures in shear, producing a characteristic leaf-type configuration after functioning.

The radius-edged orifice produces a tension-type actuation mode whereby the disc stretches over the radius-edge. This thins the center of the disc until it can no longer hold the pressure. This type of rupture produces a characteristic rose petal configuration after functioning.

Since the actuation modes of each type of holder described above are completely different, it is important that only original manufacturer's assemblies be used in the replacement of rupture disk devices.



WARNING The pressure relief rupture disk device is a primary safety component and hence the following precautions should be noted and adhered to:

- A. Only trained personnel should be permitted to service pressure relief devices
- B. Tightening of the rupture disk assembly to the cylinder valve or to the cylinder itself should be in accordance with the manufacturer's instructions. Tightening to a torque less than the manufacturer's recommendations may result in a leaking device or a device that may rupture at a lower pressure than specified. Conversely, over tightening can also result in disk actuation at a lower pressure than specified due to excessive twisting action, which may create wrinkles or distortions in the disk, which may cause premature failure of the disk and inadvertent release of the pressure contents. Either of these premature releases could cause serious injury or death.



WARNING Components of devices designed to rupture in shear are very similar in appearance to those designed to rupture in tension but are not interchangeable because they have completely different modes of actuation. If components are inadvertently interchanged, i.e. a disk designed to rupture in shear is installed in a rupture disk holder designed to rupture in tension, a serious cylinder failure incident could result that could lead to loss of life due to the significant increase in pressure required to rupture the disk. Conversely if a disk designed to rupture in tension is installed in a rupture disk holder designed to rupture in shear, premature rupture could occur with complete loss of contents due to significant reduction in rupture pressure of the disk. That may lead to fire, personal injury or death.

Limitations

A rupture disk is a pressure-operated device which affords protection against excessive pressure. It protects against excessive pressure when the properties of the gas, cylinder design, and percentage of charge in the cylinder are such that exposure to excessively high temperatures will cause an increase in internal pressure sufficient to actuate the rupture disk

Pressure Relief Devices Technical Information

before the cylinder loses its integrity and weakens. The rupture disk also protects against excessive pressure due to improper charging practices such as overfilling.

A rupture disk is a non-reclosing device. Once the disk has ruptured, there is no way to prevent the complete release of the contents of the cylinder.

This device does not provide good protection against pressures caused by exposure to excessively high temperatures when the cylinder is only partially charged. The pressure rise may not be sufficient to actuate the rupture disk before the cylinder loses its integrity and weakens.

Consideration should be given to environmental conditions to which the cylinder may be exposed. Severely corrosive atmospheres may contribute to premature rupture of the disk. To prevent corrosion of the rupture disk, care must be taken to select materials of construction that do not interact with either the contents of the cylinder or the anticipated environmental conditions.

Type CG-2 and CG-3 (Fusible Plugs)

A fusible plug is a thermally operated pressure relief device which affords protection against excessive pressure developed by exposure to excessive heat. Once sufficient heat melts the fusible alloy, the entire contents of the cylinder will be vented. The CG-2 fusible alloy has a nominal melt temperature of 165° F (73.9° C); the CG-3 fusible metal has a nominal melt temperature of 212° F (100° C).

Fusible plugs can be installed on the cylinder as independent devices or fusible alloy can be cast directly into a suitable orifice in the cylinder valve body. In some cases, a fusible plug may be installed as a separate device into the cylinder valve body.

WARNING No attempt should be made to repair fusible plug devices. They are not repairable and attempts to repair will destroy the integrity of the fusible alloy causing leakage of gases that may lead to fire, personal injury or death.

Limitations:

Since the fusible plus is a thermally operated device, it is designed to function only when the fusible metal melts out. Hence, it does not protect against over pressure from improper charging practices. Sufficient heat to melt the fusible alloy is necessary for proper functioning of this type of device. Therefore, the location of such devices is an important consideration. Industry practice limits the application of these style fusible plugs to cylinders with 500 psig (3447 kPa) service pressure or less to minimize the possibility of cold flow or extrusion of the fusible alloy. A fusible device is a nonreclosing devices and when it functions, it releases the entire contents of the cylinder.

Type CG-4 and CG-5 (Combination Rupture Disk/Fusible Plug)

A combination rupture disk/fusible plug pressure relief device requires both excessive pressure and excessive temperature to cause it to operate. Sufficient heat is required to first melt out the fusible metal, after which the device will afford the same protection as the CG-1 rupture disk device.

The CG-4 combination device has fusible alloy with a nominal melt temperature of 165° F (73.9° C). The CG-5 combination device has fusible alloy with a nominal melt temperature of 212° F (100° C).

In this type of device, the rupture disk portion (CG-1) is directly exposed to the internal cylinder pressure, and so it is directly upstream of the fusible metal. In general, the same components that make up the CG-1 device are used and the vent portion or downstream side of the rupture disk is thus reinforced against rupturing by the fusible alloy, and the fusible alloy is reinforce against extrusion by the rupture disk.

NOTE: The same precautions noted for CG-1 devices should be adhered to for CG-4 and CG-5 device. See previous warnings.

Limitations:

CG-4 and CG-5 combination devices function only in the presence of both excessive heat and excessive pressure, and sufficient heat must be present first to melt the fusible metal. Therefore, this device does not offer protection against over pressure from improper charging practices.

Type CG-7 (Pressure Relief Valves)

A pressure relief valve is a spring-loaded pressure-operated device designed to relieve excessive cylinder pressure, reclose, and reseal to prevent further release of product from the cylinder after excessive pressure is removed and valve resealing pressure has been achieved.

The primary advantage of using the pressure relief valve is that functioning of this type of device may not release all of the contents of the cylinder but is designed to reseal after resealing pressure has been achieved. This characteristic, in fire conditions, will minimize feeding the fire in the case of flammable or combustible cylinder contents.

Limitations:

Pressure relief valves are designed to maintain the pressure in the cylinder at a limit as determined by the spring force. Therefore, such devices do not protect the cylinder against possible rupture when continued application of external heat or direct flame impingement weakens the cylinder wall to the point where its rupture pressure is less than the operating pressure of the relief valve.

If you require assistance in selecting a Pressure Relief or Safety device for a specific application, please contact Sherwood Customer Service at 888-508-2583 with the following information: Part number of the valve assembly being repaired, if applicable; Type of gas service in which cylinder will be used; and service or test pressure of the cylinder.

Pressure Relief Device Numbering Matrix: Unitized Plug Series

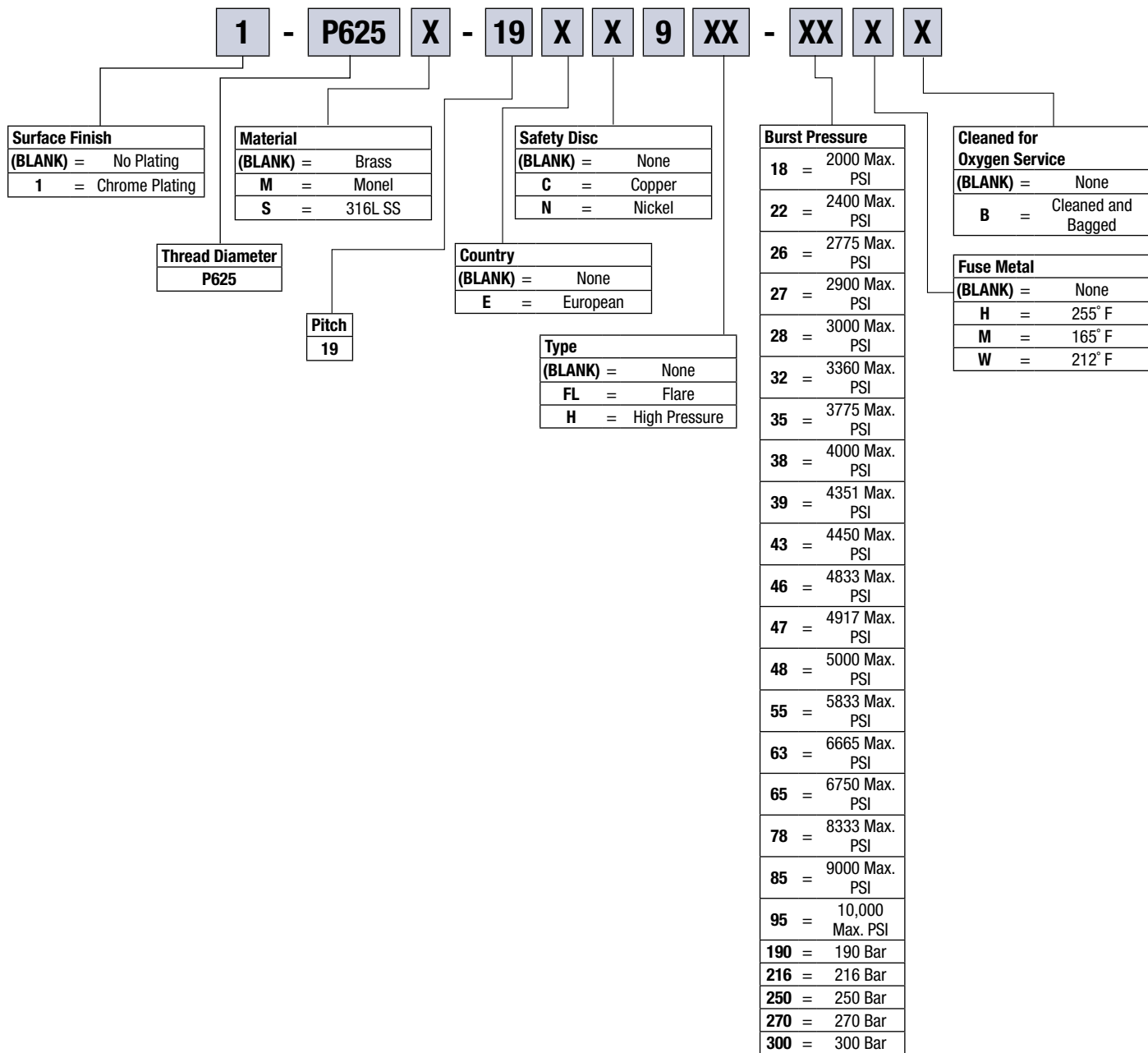

Product Markings Reference

Product Markings Reference

A GV, GVHM, MVHM, GV Acetylene, GVT and NGV Series

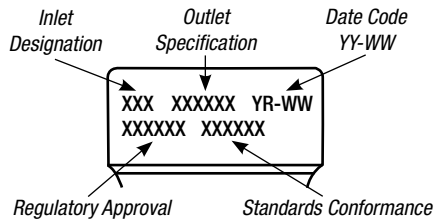

NOTE: For European valves, there may be a third line designating Bar pressure rating.

C AV Handwheel-Operated Series

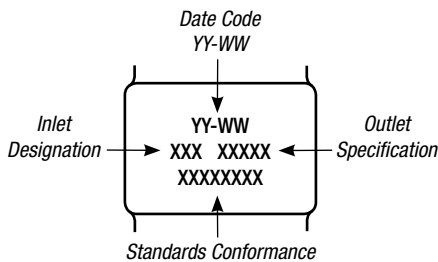

E NBV Series

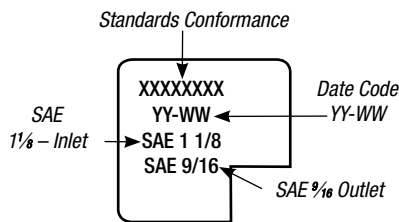

B GRPV Series

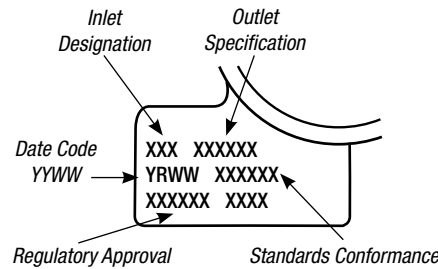

D 5983L, 1206A and 1031 Series

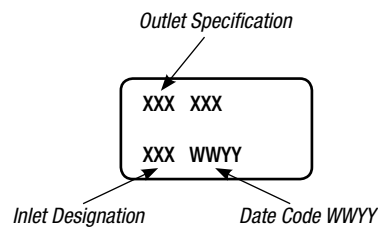

F Date Code Stamping Standard for BV, AV Wrench-Operated, YVBA, PVE3250, YVE, DF, YVA, PVE, PA and RVE Series

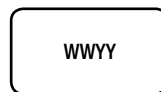

First two characters indicated the week of the calendar year the product was manufactured. For example: 01 – first week of calendar year or 10 – tenth week of calendar year. Last two characters indicate the last two digits of the year manufactured.

Inlet Code	
Inlet Code	Inlet Thread Designation
4FPT	1/4"–18 NPT Female
06N	3/8"–18 NGT
8MPT	1/2"–14 NPT
08N	1/2"–14 NGT
12FPT	3/4"–14 NPT Female
12N	3/4"–14 NGT
12S	3/4"–14 SGT
16N	1"–11 1/2 NGT
U8	1/2"–20 UNF
U10	3/8"–18 UNF
SP12	3/4"–14 NPSM
U12	3/4"–16 UNF
U14	7/8"–14 UNF
U18	1 1/8"–12 UNF
17E	17,4 ISO/DIS 11116
198	DIN 477 W18,8 x 1/4
25E	25,8 ICO/DSI 10920.2 & DIN 477 28,8 x 1/4
313	DIN 477 W31,3 x 1/4
V1	20 X 14 JIS B 8246
V2	28 X 14 JIS B 8246
V3	28 X 14 JIS B 8246 (Reduced Length)
W6	0.06–14 AS2473
W71	0.715–14 AS2473
W1	1–14 AS2473
18P	M18 x 1,5
25P	M25 x 2

Outlet Codes	
Code	Description
CGA	CGA Outlet
ABN	Brazil, ABNT
AS	Australia, AS2473
BS	British Standard
DIN	Germany
IND	Chile, Indura
INF	Mexico, INFRA
IRA	Argentina, IRAM
JIS	Japan
NF	France
SMS	Sweden

NOTE: Date codes include the last two digits of the year manufactured and two digits to represent the week manufactured. For example, the year is represented as "08" for 2008 or "10" for 2010. For example, the week is represented as "01" for first week of the year manufactured and "10" for tenth week of the year manufactured. In some standards the year comes first, and in some standards the week comes first.

KVAB and KVBM Medical Valves Date Code Tables

1983			
Date Code	Month	Year	Examples
<p>In 1983, the date code was controlled by Sherwood drawing 3095, rev C. The date code was a simple three-character code representing month and year. Month was the first character, represented by a letter of the alphabet with A being January, B being February, etc. Note that the letter I was used (for September) so the plan ended with L = December.</p> <p>The final two characters were a numeric representation of the year with 83 = 1983, 84 = 1984, etc.</p>	A = January	83 = 1983	A83 = January, 1983
	B = February	84 = 1984	G84 = July, 1984
	C = March	85 = 1985	
	D = April	...	
	E = May		
	F = June		
	G = July		
	H = August		
	I = September		
	J = October		
	K = November		
	L = December		

1989			
Date Code	Week	Year	Examples
<p>In 1989, drawing 3095 was revised to Rev D. It now included the option of a weekly code instead of the monthly code. This option was used on the K valves.</p> <p>01 was used to indicate the first week of the calendar year, 02 the second week, 03 the third week, etc.</p>	01 = 1st week	89 = 1989	01-89 = 1st week of 1989
	02 = 2nd week	90 = 1990	13-89 = 13th week of 1989
	03 = 3rd week	91 = 1991	...
	04 = 4th week		
	05 = 5th week		
	06 = 6th week		
	07 = 7th week		
	08 = 8th week		
	09 = 9th week		
	10 = 10th week		
	11 = 11th week		
	...		
52 = 52nd week			

Note that the dash may be replaced by a blank space.

1990	
Date Code	
<p>In 1990, drawing 3095 was revised to Rev E. This removed the month + year option from the drawing (was still in use for some non-K valves) and left only the week + year format. It also added an optional L "in the vicinity of the date code" to show that the valve was manufactured at the Sherwood facility in Lockport, NY. The dash (or space) between month and year was retained.</p>	

1997				
Date Code	Week	Year	Sherwood Facility	Examples
<p>In 1997, the controlling drawing was changed to STD724, Rev A. This retained the week + year format but added a single character to represent the plant where the valve was manufactured. The dash or blank space between year and week was also deleted.</p>	01 = 1st week	99 = 1999	L = Lockport, NY	1099L = 10th of 1999, manufactured at the Sherwood facility in Lockport, NY
	02 = 2nd week	00 = 2000	W = Washington, PA	0200W = 2nd week of 2000, manufactured at the Sherwood facility in Washington, PA
	03 = 3rd week	01 = 2001	Blank = Niagara Falls, NY	5101 = 51st week of 2001; the lack of a plant location character at the end means that the valve was manufactured at the Sherwood facility in Niagara Falls, NY
	04 = 4th week			
	05 = 5th week			
	06 = 6th week			
	07 = 7th week			
	08 = 8th week			
	09 = 9th week			
	10 = 10th week			
	11 = 11th week			
	...			
52 = 52nd week				

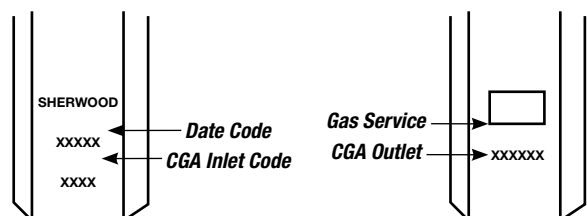

KVAB and KVBM Medical Valves Date Code Tables

KVAB and KVMB Medical Valves Date Code Tables

2002				
Date Code	Shift	Year	For Non-Leap Years	Examples
<p>In 2002, the controlling drawing was changed to STD724B. This changed the date code to include the shift, the day number of the year and the year.</p> <p>For the first character, 1 = first shift, 2 = second shift and 3 = third shift. The second character is a letter to represent the year. A = 2002, B = 2003, C = 2004. The letter I is not used (because of its similarity to the numeral 1), so H = 2009 and J = 2010. The character O is also not used (similarity to 0), so N = 2014 and P = 2015.</p> <p>The final three characters represent the day of the year. 001 = January 1, 032 = February 1 and 365 = December 31.</p>	1 = 1st shift	A = 2002	001 = January 1	1A001 = 1st shift, 2002, January 1
	2 = 2nd shift	B = 2003	002 = January 2	2B181 = 2nd shift, 2003, June 30
	3 = 3rd shift	C = 2004	003 = January 3	3C213 = 3rd shift, 2004, July 31
		D = 2005	
		E = 2006	031 = January 31	
		F = 2007	
		G = 2008	059 = February 28	
		H = 2009	060 = March 1	
		J = 2010	
		K = 2011	090 = March 31	
		L = 2012	091 = April 1	
		M = 2013	
		N = 2014	365 = December 31	
		P = 2015		
		Q = 2016	For Leap Years	
		R = 2017	001 = January 1	
		S = 2018	002 = January 2	
		T = 2019	003 = January 3	
		U = 2020	
		V = 2021	031 = January 31	
			
	059 = February 28			
	060 = February 29			
	061 = March 1			
			
	091 = March 31			
	092 = April 1			
			
	366 = December 31			

DOs and DO NOTs for Valve Use

Source: Compressed Gas Association, Inc. CGA V-9, 2012, p. 39

DOs

Proper care of compressed gas cylinder valves includes (but is not limited to) the following:

- Stored valves shall be packaged so cleanliness is maintained and adequate protection against damage during handling is provided.
- Valves should be visually inspected at each refill for any signs of damage or leakage.
- Question the supplier when a valve malfunctions and the problem cannot be diagnosed.
- Inspect PRDs per CGA S-1.1 before each refilling.
- Verify that a particular valve is suitable for both the cylinder and the commodity with which it is intended to be used.
- Open the valve slowly to prevent development of high pressure surges and heat generation on downstream equipment.
- When replacing PRDs, only original manufacturers' assemblies and parts shall be used unless the interchange of parts is proven by suitable test.
- When replacing PRDS, refer to the marking on the device to ensure the proper rated device is installed.
- When the cylinder is not in use, even when empty, the valve should be in the closed position with the outlet cap in place and the transport cap installed.
- Check the condition of both the inlet and outlet threads before inserting a valve into a cylinder to ensure that the threads are not damaged, especially the first thread. A damaged first inlet thread could adversely affect insertion. If the damage cannot be repaired by manually deburring with a file, replace the valve.
- Handle valves carefully to avoid damage, especially to threads, which could prevent proper connection to mating parts.
- Replace the valve or PRD whenever any of its required markings are no longer legible.
- Valves that are shipped not fully assembled or with unattached components shall be protected from contamination.
- Only lubricants specially prepared for oxygen service shall be used on tapered threaded inlet connections.

NOTE: Not all PTFE tapes are suitable for oxygen service. Only PTFE tapes suitable for oxygen service shall be used.

DO NOTs

This list is not intended to be comprehensive. The user is cautioned to review maintenance activity with the valve supplier before beginning work if there is any uncertainty on the part of the user.

Proper care of compressed gas valves includes the following:

- Do not use a damaged valve where function or integrity might have been affected.
- Do not continue to use a valve that operates abnormally, such as it becoming noisy or progressively harder to operate.
- Do not try to recondition a valve until the design and operations of the valve are fully understood and the proper tools are available.
- Do not reuse a valve having a tapered inlet thread with less than four full threads showing after it is installed into the cylinder hand-tight.
- Do not use an automatic operator, adapter, wrench or other tool to obtain a greater mechanical advantage on handwheel-operated valves without first consulting with the valve manufacturer to ensure that the applied torque does not exceed the safe operating torque for the valve.
- Do not use the number of exposed valve threads to determine whether a valve is adequately engaged and leak tight in a cylinder. (See CGA V-11, General Guidelines for the Installation of Valves into High Pressure Aluminum Cylinders, for valve installed in aluminum cylinders.) Even with a new valve in a new steel cylinder, both with nominal 3/4"-14 NGT threads, the number of exposed full threads after three wrench turns can vary between two and five.
- Do not lubricate valve internal surfaces with the pressure boundary without first checking with the valve manufacturer.
- Do not lubricate oxygen service valve threads (to cylinder threads) for installation in straight-threaded aluminum.
- Do not use poor fitting jaws on valving machines because they could cause:
 - Excessive bending and torsional forces into the valve
 - Rounding off of valve wrench flat corners with obliteration of valve identification markings, or
 - Interference of jaws with valve outlet, PRD, etc., resulting in damage and leaks
- Do not attempt to adjust spring-loaded (CG-7) PRDs because they are not adjustable once set at the factory. Adjustments result in damage to the PRD as well as the valve itself.
- Do not lift, drag or move a cylinder using the valve handwheel as a handle. It is not designed for this purpose and doing so can cause the valve to open.
- Do not use adapters to adapt the CGA valve outlet connection to another CGA valve outlet connection unless adapters satisfy the conditions for their use specified in CGA V-1.
- Do not put a reconditioned valve into service unless it has been tested to this standard.
- Do not use internal operating replacement parts unless they were supplied by the valve manufacturer.

Valve Part Numbering Matrix: Global Valves

GV A X 0 6 1 - 38 B

Valve Category	
GV	= Global CG Valve
GRFY	= Global Residual Pressure Valve
GVM	= Global CG Valve with Double O-Ring
GVHM	= Global High-Pressure Valve with Double O-Ring
NGV	= Global Valve for Hydrocarbon-Based Gases
NGVHM	= Global Valve for High-Pressure Hydrocarbon-Based Gases

Outlet Designation
Letter or Number from the Associated Specification

Safety Type
0 = No Safety
1 = Unbacked Frangible Disc
2 = 165° Fuse Plug
3 = 212° Fuse Plug
4 = Backed Frangible Disc with 165° Fusible Metal
5 = Backed Frangible Disc with 212° Fusible Metal
H = Backed Frangible Disc with 255° Fusible Metal

Safety Pressure
18 = 2000 Max. PSI
22 = 2400 Max. PSI
26 = 2775 Max. PSI
27 = 2900 Max. PSI
28 = 3000 Max. PSI
32 = 3360 Max. PSI
35 = 3775 Max. PSI
38 = 4000 Max. PSI
39 = 4351 Max. PSI
43 = 4450 Max. PSI
46 = 4833 Max. PSI
47 = 4917 Max. PSI
48 = 5000 Max. PSI
55 = 5833 Max. PSI
63 = 6665 Max. PSI
65 = 6750 Max. PSI
78 = 8333 Max. PSI
85 = 9000 Max. PSI
95 = 10,000 Max. PSI
190 = 190 Bar
216 = 216 Bar
250 = 250 Bar
270 = 270 Bar
300 = 300 Bar

Special Features	
00 = Safety Port Machined Safety Not Installed	
B = Cleaned for O ₂ Service and Bagged	
CC = Cap and Chain	
FT = Filter	
GH = Gauge Hole	
HC = Rubber Handwheel Cover	
LX = Lexan® Handwheel	
MA = Stamped: Argon	
MB = Stamped: Air Breathing	
MC = Stamped: Carbon Dioxide	
MD = Stamped: CO ₂ Med.	
MG = Stamped: Acetylene	
MM = Stamped: Carbon Monoxide	
MN = Stamped: Nitrogen O.F.	
MO = Stamped: Oxygen	
MQ = Stamped: Oxygen-Hel. Med.	
MR = Stamped: Air Industrial	
MS = Stamped: Sulphur Hexafluoride	
MY = Stamped: Hydrogen	
M1 = Stamped: Inert O.F.	
M2 = Stamped: Inert O.T.	
M3 = Stamped: Nitrous Oxide Med.	
M4 = Stamped: Oxygen Med.	
M7 = Stamped: 6000 PSI	
T = 1/4" NPT Tapped Inlet	
VS = Vented Flare Safety (Hydrogen)	
-3 = 3 Threads Oversize	
-4 = 4 Threads Oversize	
-7 = 7 Threads Oversize	
-24 = 24 Threads Oversize	
When Inlet Designation is 5	
-50 = .500-20 UNF Inlet Thread	
-62 = .625-18 UNF Inlet Thread	
-75 = .750-16 UNF Inlet Thread	
-87 = .875-14 UNF Inlet Thread	

Plating
(BLANK) = Unplated
A = Chrome Plated

Outlet Code
(NONE) = CGA Outlet
ABN = Brazil, ABNT
AS = Australia, AS2473
BS = British Standard
DIN = Germany
IND = Chile, INDURA
INF = Mexico, INFRA
IRA = Argentina, IRAM
JIS = Japan
NF = France
SMS = Sweden

Inlet Designation
3 = 3/8"-18 NGT
4 = 1/2"-NGT
4FPT = 1/4"-18 NPT Female
5 = Straight Thread, 1 1/8"-12 UNF (Unless Changed by Special Feature)
6 = 3/4"-14 NGT
7 = 3/4"-14 SGT
8 = 1"-11 1/2 NGT
8MPT = 1/2"-14 NPT
12FRT = 3/4"-14 NPT Female
17E = 17,4 ISO/DIS 11116
18P = M18 x 1,5
25E = 25,8 ISO/DIS & DIN 28,8
25P = M25 x 2
198 = DIN W19,8
313 = DIN W31,3
SP12 = 3/4"-14 NPSM
V1 = JIS 20 x 14
V2 = JIS 28 x 14
V3 = JIS 28 x 14 Reduced Length
W1 = 1-14 AS2473
W6 = 0.06-14 AS2473
W71 = 0.715-14 AS2473

Valve Part Numbering Matrix: DF Series

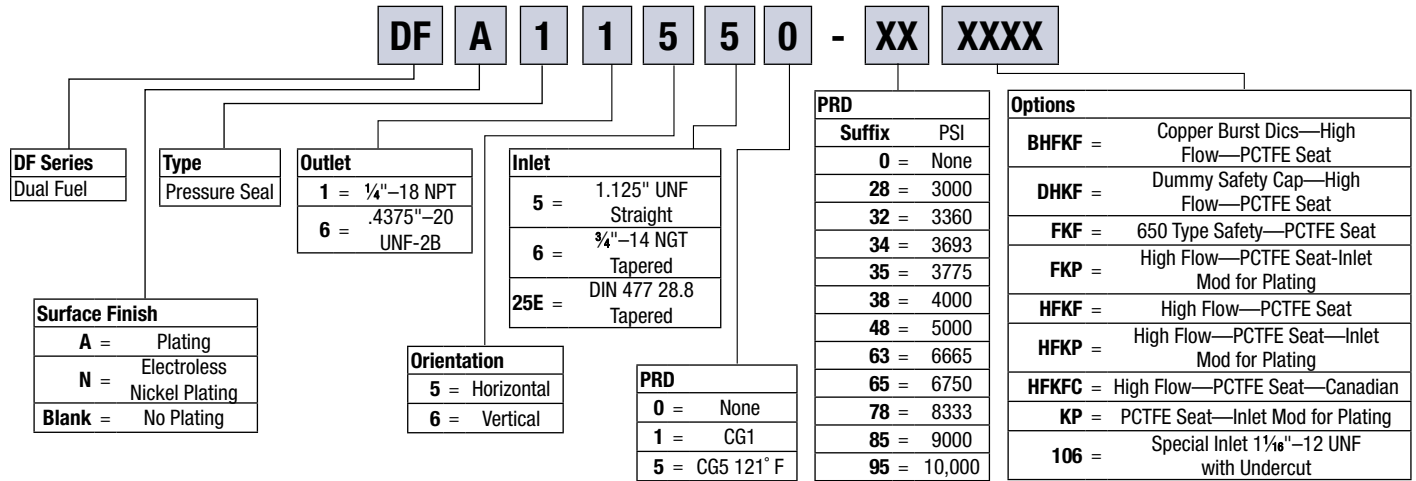

Appendix

Cylinder Valve Selection

Quick Reference for Valve Abbreviations

Use the Sherwood Cylinder Valve Series Abbreviation Chart on this page with the Sherwood Cylinder Valve Selection Charts found on **pages 73–80**. The Sherwood Cylinder Valve Selection Chart are for reference only and list:

- The most commonly used gases
- The Compressed Gas Association primary outlet to be used with each gas
- The Sherwood valves designated for use with this gas
- The Pressure Relief Device styles that are authorized by the DOT for use with these gases

PLEASE NOTE: The Sherwood Cylinder Valve Selection Charts are partial lists extracted from the CGA V-1 and S-1.1 pamphlets. They can change without notice as the CGA V-1 and S-1.1 pamphlets are amended. Sherwood will issue periodic changes to the catalog. If there is any discrepancy or question between these lists and the CGA V-1 and S-1.1 pamphlets, the CGA V-1 and S-1.1 pamphlets take precedence.

Sherwood Cylinder Valve Series Abbreviation Chart

Abbreviation	Sherwood Valve Series
AVB	Small Cylinder Acetylene Wrench-Operated Valves
AVBHW	Small Cylinder Acetylene Handwheel-Operated Valves
AVMC	Small Cylinder Acetylene Wrench-Operated Valves
AVMCHW	Small Cylinder Acetylene Handwheel-Operated Valves
AVWB	Small Cylinder Acetylene Wrench-Operated Valves — WB Style
BV	Hi/Lo Valves with Built-in Regulator
DF*	Alternative Energy Valves
GRPV	Residual Pressure Valves
GV	Large Cylinder Acetylene Valves
GVT**	Vertical Outlet Acetylene Valves
KVAB	Post Medical Valves
KVMB	Post Medical Valves
NGV	Industrial and Chrome-Plated Valves
YVB†	Vertical Outlet Oxygen Valves

* DF Valves can be used with all gases; however, the outlet will always be ¼"–18 NPT female.

** Acetylene use only.

† Oxygen use only.

PLEASE NOTE: Standard valves with oxygen outlet connections have been cleaned for oxygen service. These valves are routed through the specialized manufacturing process at Sherwood Valve following written standards and protocols. This process includes the cleaning of components and the tight control of assembly operations avoiding contamination. These valves are cleaned as part of our standard operating procedure and have been validated to meet the oxygen cleaning requirements as specified in the Compressed Gas Association CGA G-4.1.

Cylinder Valve Selection

Acetylene – Chlorine Trifluoride

Sherwood Cylinder Valve Selection Chart										
Gas Name PSI (KPa)	FTSC Code (see p. 80)	CGA Outlet	Sherwood Valve Series (see Abbreviation Chart on p. 72)							Pressure Relief Devices (see p. 79)
			AVB & AVBHW	AVMC & AVMCHW	AVWB	BV	GRPV	GV	KV	
Acetylene*	5130									
>50 cu. ft. (1.39 m ³)		510			•				•	CG-3
35–75 cu. ft. (970 L–2.08 m ³)		520	•							CG-3
-10 cu. ft. (280 L)		200		•						CG-3
Air (R729)	1060									
0–3000 (0–20,680) Threaded		346					•		•	CG-1, -4, -5
0–3000 (0–20,680) Yoke		950							•	CG-1, -4, -5
3001–4700 (20,690–32,400)		347					•		•	CG-1, -4, -5
4701–6400 (32,412–44,126)		702							•	CG-1, -4, -5
Allylene (see Methylacetylene)										
Argon	1060									
0–3000 (0–20,680)		580					•		•	CG-1, -4, -5
3001–4700 (20,690–32,400)		680					•		•	CG-1, -4, -5
4701–6400 (32,412–44,126)		677							•	CG-1, -4, -5
Arsine	2300	350								Prohibited
Boron Fluoride (see Boron Trifluoride)										
Boron Trifluoride	0263	330								Prohibited
Bromine Pentafluoride	4303	670							•	Prohibited
Bromine Trifluoride	0263	670							•	Prohibited
Bromochlorodifluoromethane (R12B1)	0100	660							•	CG-1, -2, -3, -7
Bromoethylene (see Vinyl Bromide)										
Bromomethane (see Methyl Bromide)										
Bromotrifluoroethylene (R113B1)	3100	510								CG-1
Bromotrifluoromethane (R13B1)	0100									
Butane (R600)	2100									
		660							•	CG-1, -7
Gas Withdrawal		510								CG-7
Liquid Withdrawal		555								CG-7
1-Butene	2100	510								CG-7
2-Butene	2100	510								CG-7
Butylene (see 1-Butene)										
Butylene (see 2-Butene)										
1-Butyne (see Ethylacetylene)										
Carbon Dioxide (R744)	0110									
Threaded		320							•	CG-1, -4
Yoke		940								CG-1
Carbonic Acid (see Carbon Dioxide)										
Carbon Monoxide	2260	350						•	•	
Carbon Oxysulfide (see Carbonyl Sulfide)										
Carbon Tetrafluoride (see Tetrafluoromethane)										
Carbonyl Chloride (see Phosgene)										
Carbonyl Fluoride	0213	660								N.R. CG-4
Carbonyl Sulfide	2201	330								CG-2, -4
Chlorine	4203									
Threaded		820								CG-2
Yoke		820								CG-2
Chlorine Pentafluoride	4303	670								Prohibited
Chlorine Trifluoride	4203	670								CG-4

* Acetylene is the only gas in this table that is not specified by gas pressure; it is specified by volumetric units.

** DF Valves can be used with all gases; however, the outlet will always be 1/4"–27 NPT female.

Appendix

Cylinder Valve Selection

1-Chloro-1, 1-Difluoroethane (R142b) – Ethylene Oxide

Gas Name PSI (KPa)	FTSC Code (see p. 80)	CGA Outlet	Sherwood Valve Series (see Abbreviation Chart on p. 72)							Pressure Relief Devices (see p. 79)
			AVB & AVBHW	AVMC & AVMCHW	AVWB	BV	GRPV	GV	KV	
1-Chloro-1, 1-Difluoroethane (R142b)	2100	510								CG-2, -3, -7
Chlorodifluoromethane (R22)	0100	660								CG-1, -2
Chloroethane (see Ethyl Chloride)	0100									
Chloroethylene (see Vinyl Chloride)										
Chloromethane (see Methyl Chloride)										
Chloropentafluoroethane (R115)	0100	660						•		
1-Chloro-1,2,2,2-Tetrafluoroethane (R124)	0100	660						•		
1-Chloro-2,2,2-Trifluoroethane (R133a)	5200	660						•		
Chlorotrifluoroethylene (R1113)	0100									
Chlorotrifluoromethane (R13)	0100	660						•		
Cyanogen	2200	660						•		
Cyanogen Chloride	0303	660								
Cyclobutane	2100	510								
Cyclopropane	2100									
Threaded		510						•		
Yoke		920							•	
Deuterium	2160	350						•		
Diborane	5360	350						•		
Dibromodifluoroethane	1100	660								N.R.
Dibromodifluoromethane (R12B2)	0100	660						•		N.R.
1,2-Dibromotetrafluoroethane (R114B2)	0100	660						•		N.R. CG-1
1,2-Dichlorodifluoroethylene	0100	660						•		N.R.
Dichlorodifluoromethane (R12)	0100	660						•		CG-1, -2, -3, -7
Dichlorofluoromethane (R21)	0100	660						•		N.R. CG-1
1,1-Dichlorotetrafluoroethane (R114a)	0100	660						•		N.R. CG-1
1,2-Dichlorotetrafluoroethane (R114)	0100	660						•		N.R. CG-1
2,2-Dichloro-1,1, 1-Trifluoroethane (R123)	0100	660						•		N.R.
Dicyane (see Cyanogen)										
Diethylzinc	3300	510								Prohibited
Difluorodibromoethane (see Dibromodifluoroethane)										
Difluorodibromomethane (see Dibromodifluoromethane)										
1,1-Difluoroethane (R152a)	N/A	510								CG-2, -3, -7
1,1-Difluoroethylene (R1132a)	2110	350								CG-1, -4
Difluoromonochlorethane (see Chlorodifluoroethane)										
Dinitrogen Oxide (see Nitrous Oxide)										
Dinitrogen Tetroxide (see Nitrogen Dioxide)										
Dinitrogen Trioxide (see Nitrogen Trioxide)										
Diphosgene	0303	660								Prohibited
Epoxyethane (see Ethylene Oxide)										
Ethane (R170)	2110	350						•		CG-1
Ethene (see Ethylene)										
Ethylacetylene	2100	510								N.R. CG-2
Ethylamine (see Monoethylamine)										
Ethyl Chloride (R160)	2100	300								N.R. CG-2
Ethylene (R1150)	2160									
Threaded	350							•		CG-1
Yoke	900								•	CG-1
Ethylene Oxide	5120	510								See CFR49 173.323

** DF Valves can be used with all gases; however, the outlet will always be ¼"–27 NPT female.

Cylinder Valve Selection

Ethylidene Fluoride – Methane (R50)

Sherwood Cylinder Valve Selection Chart

Gas Name PSI (KPa)	FTSC Code (see p. 80)	CGA Outlet	Sherwood Valve Series (see Abbreviation Chart on p. 72)							Pressure Relief Devices (see p. 79)
			AVB & AVBHW	AVMC & AVMCHW	AVWB	BV	GRPV	GV	KV	
Ethylidene Fluoride (see 1,1-Difluoroethane)										
Ethyne (see Acetylene)										
Fluorine	4343	679								Prohibited
Fluoroethylene (see Vinyl Fluoride)										
Fluoroform (R23) (see Trifluoromethane)										
Fluoromethane (see Methyl Fluoride)										
Gases in Small Cylinders (see "Introduction" Par. 2.10 in CGA pamphlet V-1-1994)										
Germane	2300	350								Prohibited
Helium	0160									
0–3000 (0–20,680) Threaded		580				•	•	•		CG-1, -4, -5
0–3000 (0–20,680) Yoke		930							•	CG-4
3001–4700 (20,690–32,400)		680				•	•	•		CG-1, -4, -5
4701–6400 (32,412–44,126)		677					•	•		CG-1, -4, -5
Hexafluoroethane (R116)	0100	660					•	•		CG-1, -4
Hexafluoro-2-Propanone (see Hexafluoroacetone)										
Hexafluoropropylene (R1216)	0100	660								CG-1
Hydrobromic Acid, Anhydrous (see Hydrogen Bromide)										
Hydrochloric Acid, Anhydrous (see Hydrogen Chloride)										
Hydrofluoric Acid, Anhydrous (see Hydrogen Fluoride)										
Hydrogen	2160									
0–3000 (0–20,680) Threaded		350					•	•		CG-4, -5
3001–4700 (20,690–32,400)	695							•	•	CG-4, -5
4701–6400 (32,412–44,126)	703							•	•	CG-4, -5
Hydrogen Bromide	0203	330								CG-4
Hydrogen Chloride	0213	330								CG-4
Hydrogen Fluoride	0203	670								N.R.
Hydrogen Selenide	2300	350								Prohibited
Hydrogen Sulfide	2201	330								CG-2, -4
Iodine Pentafluoride	4303	670								Prohibited
Isobutane (R601)	2100	510								CG-7
Isobutene (see Isobutylene)										
Isobutylene	2100	510								CG-7
Krypton	0160									
0–3000 (0–20,680)		580				•	•	•		CG-1, -4, -5
3001–4700 (20,690–32,400)		680				•	•	•		CG-1, -4, -5
4701–6400 (32,412–44,126)		677				•	•	•		CG-1, -4, -5
Laughing Gas (see Nitrous Oxide)										
Liquid Dioxide (see Nitrogen Dioxide)										
Marsh Gas (see Methane)										
Medical Gas Mixture										
Methane (R50)	2160									
0–500 (0–3450)		510								CG-7
0–3000 (0–20,680)		350					•	•		CG-1, -4, -5
3001–4700 (20,690–32,400)	695						•	•		CG-1, -4, -5
4701–6400 (32,412–44,126)		703					•	•		CG-1, -4, -5

** DF Valves can be used with all gases; however, the outlet will always be 1/4"–27 NPT female.

Appendix

Cylinder Valve Selection

Methanethiol – Oxirane

Sherwood Cylinder Valve Selection Chart

Gas Name PSI (KPa)	FTSC Code (see p. 80)	CGA Outlet	Sherwood Valve Series (see Abbreviation Chart on p. 72)							Pressure Relief Devices (see p. 79)
			AVB & AVBHW	AVMC & AVMCHW	AVWB	BV	GRPV	GV	KV	
Methanethiol (see Methyl Mercaptan)										
Methoxyethylene (see Vinyl Methyl Ether)										
Methylacetylene	2100 510									CG-7
Methyl Bromide	0200	330								N.R.
Methyl Chloride (R40)	2100	510								CG-7
Methylene Fluoride (R32) (Difluoromethane)	2110	350						•		CG-1, -7
Methyl Fluoride (R41) (Fluoromethane)	2103	350						•		CG-4
Methyl Mercaptan	2201	330								N.R.
2-Methylpropene (see Isobutylene)										
Methyl Vinyl Ether (see Vinyl Methyl Ether)										
Monochlorodifluoromethane (see Chlorodifluoromethane)										
Monochloropentafluoroethane (see Chloropentafluoroethane)										
Monochlorotetrafluoroethane (see Chlorotetrafluoroethane)										
Monochlorotrifluoromethane (see Chlorotrifluoromethane)										
Mustard Gas [Bis (2-Chloroethyl) Sulfide]	0303	660								Prohibited
Natural Gas	2160									
0–500 (0–3450)		510								CG-7
0–3000 (0–20,680)		350					•	•		CG-4, -5
3001–5500 (20,690–37,900)		695					•	•		CG-4, -5
5501–7500 (38,000–51,700)		703					•	•		CG-4, -5
Neon	0160									
0–3000 (0–20,680)		580					•	•		CG-1, -4, -5
3001–4700 (20,690–32,400)		680					•	•		CG-1, -4, -5
4701–6400 (32,412–44,126)		677					•	•		CG-1, -4, -5
Nickel Carbonyl	2300	660								Prohibited
Nickel Tetracarbonyl (see Nickel Carbonyl)										
Nitric Oxide	4361	660								Prohibited
Nitrogen	0160									
0–3000 (0–20,680) Threaded		580					•	•		CG-1, -4, -5
0–3000 (0–20,680) Yoke		960							•	CG-1, -4, -5
Oil Tolerant		621					•	•		CG-1, -4, -5
3001–4700 (20,690–32,400)		680					•	•		CG-1, -4, -5
4701–6400 (32,412–44,126)		677					•	•		CG-1, -4, -5
Nitrogen Dioxide	4301	660								Prohibited
Nitrogen Peroxide (see Nitrogen Dioxide)										
Nitrogen Sesquioxide (see Nitrogen Trioxide)										
Nitrogen Tetroxide (see Nitrogen Dioxide)										
Nitrogen Trifluoride	4140	670								CG-3, -4, -5
Nitrogen Trioxide	N.A.	660								CG-3, -4, -5
Nitrous Oxide (R744a)	4110									
Threaded		326						•		CG-1
Yoke		910							•	CG-1
Octafluorocyclobutane (RC318)	0100	660								CG-7
Octafluoropropane (R218)	0100	660						•		CG-1, -7
Oxirane (see Ethylene Oxide)										

** DF Valves can be used with all gases; however, the outlet will always be 1/4"–27 NPT female.

Cylinder Valve Selection

Oxygen – Tungsten Hexafluoride

Sherwood Cylinder Valve Selection Chart											
Gas Name PSI (KPa)	FTSC Code (see p. 80)	CGA Outlet	Sherwood Valve Series (see Abbreviation Chart on p. 72)							Pressure Relief Devices (see p. 79)	
			AVB & AVBHW	AVMC & AVMCHW	AVWB	BV	GRPV	GV	KV		
Oxygen	4060										
0–3000 (0–20,680) Threaded		540						•	•		CG-1, -4, -5
0–3000 (0–20,680) Yoke		870								•	CG-1, -4, -5
3001–4700 (20,690–32,400)		577						•	•		CG-1, -4, -5
4701–6400 (32,412–44,126)		701						•	•		CG-1, -4, -5
Oxygen Difluoride	4343	679									Prohibited
Pentaborane	3300	350									Prohibited
Pentafluoroethane (HFC-125)	0100	660							•		CG-1, -7
Perfluorobutane (FC-3-1-10) (R-610)	0100	660							•		N.R. CG-2, -7
Perfluor-2-Butene	0100	660							•		N.R. CG-2
Perfluorocyclobutane (see Octafluorocyclobutane)											
Perfluoroethane (see Hexafluoroethane)											
Perfluoropropane (see Octafluoropropane)											
Phosgene	0303	660									Prohibited
Phosphine	3310										Prohibited
	350										Prohibited
Propane (R290)	2100										
Gas Withdrawal		510, 810									CG-7
Liquid Withdrawal	555	CG-7									
Propene (see Propylene)											
Propylene (R1270)	2100	510									CG-7
Propyne (see Methylacetylene)											
Silane	3160										
0–3000 (0–20,680)		350									CG-4
Silicon Tetrahydride (see Silane)											
Sulfur Dioxide (R764)	0201	660									CG-2
Sulfur Hexafluoride	0100	590						•	•		CG-1, -5
Sulfur Tetrafluoride	0303	330									Prohibited
Sulfuryl Fluoride	0200	660									CG-2
1,1,1,2-Tetrafluoroethane (R134a)	0100	167								•	CG-1
Tetrafluoroethylene (R1114)	5110	350								•	CG-1, -4
Tetrafluoromethane (R14)	0160	580								•	CG-1, -4, -5
Tetrafluorosilane (see Silicon Tetrafluoride)											
Trichlorofluoromethane (R11)	0100	660								•	N.R.
1,1,1-Trichlorotrifluoroethane	0100	660								•	N.R.
1,1,2-Trichlorotrifluoroethane (R113)	0100	660								•	N.R.
Triethylaluminum	3300	510									N.R.
Trifluorobromomethane (see Bromotrifluoromethane)											
Trifluorochloroethylene (see Chlorotrifluoroethylene)											
Trifluoromethane (HFC-23)	0110	660								•	CG-1, -4
Trifluoromethyl Chloride (see Chlorotrifluoromethane)											
Trifluoromethyl Iodide	0200	660									CG-4
Trifluorovinyl Bromide (see Bromotrifluoroethylene)											
Trimethylene (see Cyclopropane)											
Trimethylmethane (see Isobutane)											
Tungsten Hexafluoride	0303	670									N.R.

** DF Valves can be used with all gases; however, the outlet will always be 1/4"–27 NPT female.

Appendix

Cylinder Valve Selection

Uranium Hexafluoride – Xenon & Medical Gas Mixtures

Sherwood Cylinder Valve Selection Chart										
Gas Name PSI (KPa)	FTSC Code (see p. 80)	CGA Outlet	Sherwood Valve Series (see Abbreviation Chart on p. 72)							Pressure Relief Devices (see p. 79)
			AVB & AVBHW	AVMC & AVMCHW	AVWB	BV	GRPV	GV	KV	
Uranium Hexafluoride	0303	330								Prohibited
Vinyl Bromide	5100	510								N.R. CG-2
Vinyl Chloride (R1140)	5100	510								CG-2
Vinyl Fluoride (R1141)	2100	350								CG-4
Vinylidene Fluoride (see 1,1-Difluoroethylene)										
Vinyl Methyl Ether	5100	510								CG-2
Xenon	0160									
0–3000 (0–20,680)		580				•	•	•		CG-1, -4
3001–4700 (20,690–32,400)		680				•	•	•		CG-1, -4
4701–6400 (32,412–44,126)		677					•	•		CG-1, -4
Medical ① Gas Mixtures ②③ for Pressures up to 3000 (20,680)										
Carbon Dioxide and Oxygen (CO ₂ not over 7%)										
Threaded		280						•	•	CG-1, -4
Yoke		880							•	CG-1, -4
Carbon Dioxide and Oxygen (CO ₂ over 7%)										
Threaded		500						•		CG-1, -4
Yoke		940							•	CG-1, -4
Carbon Dioxide, Oxygen, Nitrogen										
Threaded		500						•		CG-1, -4
Yoke		973							•	CG-1, -4
Clinical Blood Gas Mixtures										
Threaded		500						•		CG-1, -4
Yoke		973							•	CG-1, -4
Gas Mixtures, Medical										
①③Flammable										
Threaded		350						•		CG-4
Yoke		981							•	CG-4
Gas Mixtures, Medical①③④, Nonflammable, Noncorrosive										
Threaded		500						•		CG-1, -4
Yoke		973							•	CG-1, -4
Gas Mixtures, Medical①③④, Nonflammable, Noncorrosive										
Threaded		580						•		CG-1, -4
Yoke		985							•	CG-1, -4
Helium and Oxygen (He not over 80%)										
Threaded		280						•		CG-1, -4
Yoke		890							•	CG-1, -4
Helium and Oxygen (He over 80%)										
Threaded		500						•		CG-1, -4
Yoke		930							•	CG-1, -4
Lung Diffusion Mixtures										
Threaded		500						•		CG-1, -4
Yoke		973							•	CG-1, -4
Nitric Oxide Mixtures										
Threaded		626								Prohibited

** DF Valves can be used with all gases; however, the outlet will always be 1/4"–27 NPT female.

Cylinder Valve Selection

Medical Gas Mixtures & Pressure Relief Devices

Sherwood Cylinder Valve Selection Chart										
Gas Name PSI (KPa)	FTSC Code (see p. 80)	CGA Outlet	Sherwood Valve Series (see Abbreviation Chart on p. 72)							Pressure Relief Devices (see below)
			AVB & AVBHW	AVMC & AVMCHW	AVWB	BV	GRPV	GV	KV	
Medical ② Gas Mixtures ②③ for Pressures up to 3000 (20,680)										
Nitric Oxide Mixtures and Nitrogen Dioxide Mixtures Threaded	625									Prohibited
Nitrous Oxide and Oxygen (N ₂ 47.5 to 52.5%) Threaded	280								•	CG-1, -4
Yoke	965									• CG-1, -4
Nitrogen and Oxygen (O ₂ over 23.5%) Threaded	280								•	CG-1, -4
Yoke	890									• CG-1, -4
Oxidizing Mixtures Threaded	296								•	CG-1, -4
Yoke	977									• CG-1, -4
Xenon and Oxygen (O ₂ over 20%) Threaded	280								•	CG-1, -4
Yoke	890									• CG-1, -4

** DF Valves can be used with all gases; however, the outlet will always be 1/4"-27 NPT female.

① Nominal mixture concentration; normal mixture tolerances are allowable.

② Gas mixtures labeled as drugs or medical devices and not having another connection assignment.

③ For specific gas assignments, see the reference connection number in CGA pamphlet V-1-1994.

Types of Pressure Relief Devices	
Type	Description
CG-1	Rupture Disc
CG-2	165° F (73.9° C) Fusible Plug for Cylinder Product Not Exceeding 500 PSI (3450 KPa)
CG-3	212° F (100° C) Fusible Plug for Cylinder Product Not Exceeding 500 PSI (3450 KPa)
CG-4	Rupture Disc with 165° F (73.9° C) Fusible Alloy Backing
CG-5	Rupture Disc with 212° F (100° C) Fusible Alloy Backing
CG-7	Pressure Relief Valve
CG-8	Rupture Disc Followed by (in series) a Pressure Relief Valve
CG-9	217° F (102.7° C) Fusible Plug for Cylinder Marked Working Pressure Not Exceeding 6000 PSI (41,400 KPa)
Prohibited	Prohibited from Using a Pressure Relief Device for This Gas by 49CFR100-199
N.R.	None Required
N.R. CG-	None Required, but if a Pressure Relief Device Is to Be Used, the CG- _ Style Is to Be Selected

Appendix

Cylinder Valve Selection

FTSC Numerical Code

FTSC Numerical Code for Gas Classification	
First Digit	Fire Potential
0	Inert
1	Support Combustion (Oxidizing)
2	Flammable: In Air at 68° F (20° C) and 1 Atmosphere (14.5 PSI)
3	Pyrophoric
4	Highly Oxidizing
5	May Decompose or Polymerize and Is Flammable
Second Digit	Toxicity
0	Life Supporting (oxygen > 19.5° F in simple asphyxiant)
1	LC50 > 5000 ppm
2	LC50 > 200 ppm and < 5000 ppm
3	LC50 > 200 ppm
Third Digit	State of Gas (in cylinder at 68° F [20° C])*
0	Non-Cryogenic Liquefied Gas (less than 500 PSI) (3450 KPa) ** (gas withdrawal)
1	Non-Cryogenic Liquefied Gas (less than 500 PSI) (3450 KPa) (gas withdrawal)
2	Liquefied Gas (liquid withdrawal)***
3	Dissolved Gas
4	Non-Liquefied Gas or Cryogenic Gas Withdrawal (less than 500 PSI) (3450 KPa)
5	Europe Only
6	Non-Liquefied Gas between 500 and 3000 PSI (3450 and 20,680 KPa)
7	Non-Liquefied Gas above 3000 PSI and below 10,000 PSI (20,680 and 68,900 KPa)
8	Cryogenic Gas (liquid withdrawal) above -400° F (-240° C)
9	Cryogenic Gas (liquid withdrawal) below -400° F (-240° C)
Fourth Digit	Corrosiveness
0	Non-Corrosive
1	Non-Halogen Forming Acid
2	Base Forming
3	Halogen Acid Forming

* The temperature of the refrigerated (cryogenic) liquids is always below 130° F (54.4° C).

** If pressure at 130° F (54.4° C) is over 600 PSI (4140 KPa), use digit 1.

***When a separate outlet for liquid withdrawal is specified.

Sherwood Valve, LLC Limited Warranty

Revised January 2013

Seller warrants to you, the first purchaser, that it will repair or replace, at its sole discretion, defects in materials or workmanship that occur and are reported to Seller, within the applicable warranty period, subject to the terms, conditions and exclusions set forth in this document. Your acceptance of delivery of the warranty product constitutes your acceptance of the terms of this limited warranty. This limited warranty gives you specific legal rights and you may have other rights which may vary from state to state.

This limited warranty is the sole and exclusive warranty from Seller and there are no express warranties which extend beyond those outlined in this limited warranty. Under the laws of certain states, there may be no implied warranties from Seller and ALL IMPLIED WARRANTIES (INCLUDING ANY IMPLIED WARRANTY OF MERCHANTABILITY OR FITNESS FOR A PARTICULAR PURPOSE) ARE EXCLUDED AND DISCLAIMED WHERE ALLOWED BY APPLICABLE LAW. ANY IMPLIED WARRANTIES (IF APPLICABLE) ARE LIMITED TO THE SCOPE AND MINIMUM PERIOD OF TIME ALLOWED UNDER APPLICABLE LAW.

Coverage Under This Limited Warranty:

The limited warranty period runs for one (1) year from the date the product was shipped from Seller's manufacturing plant to the first purchaser. This WARRANTY EXTENDS ONLY TO THE FIRST PURCHASER of the Seller's product and does not extend to a consumer who purchases Seller's product from a dealer or otherwise.

THIS LIMITED WARRANTY DOES NOT COVER damage caused by misuse or negligence and does not cover or apply to any product, accessory, part or attachment which is manufactured by someone other than Seller.

THE SOLE AND EXCLUSIVE REMEDY UNDER THIS LIMITED WARRANTY AND ANY APPLICABLE IMPLIED WARRANTY IS THE REPAIR OR REPLACEMENT, AT SELLER'S SOLE OPTION, OF WARRANTED PRODUCTS AS SET FORTH HEREIN. SELLER EXCLUDES AND DISCLAIMS ANY LIABILITY FOR ANY CONSEQUENTIAL, SPECIAL, OR INCIDENTAL DAMAGES RESULTING FROM THE DELIVERY, USE OR FAILURE OF THE PRODUCT (INCLUDING, WITHOUT LIMITATION, LOSS OF ANY MATERIALS STORED IN PRODUCT; ANY DISRUPTION OF BUSINESS, DISRUPTION OF MANUFACTURING OR OTHER OPERATIONS; LOSS OF REVENUE OR PROFIT OR DAMAGES RESULTING FROM ANY BREACH OF ANY CONTRACT BETWEEN BUYER AND ANY THIRD PARTY), OR FROM ANY OTHER CAUSE WHATSOEVER. Any legal action alleging breach of any applicable warranty coverage must be brought within one (1) year from the date the alleged breach first occurred.

If Buyer believes that any part of Seller's product is defective, Buyer must give written notice to Seller at the address on the reverse side of this document before the expiration of the initial warranty period, giving details as to date and place of purchase, serial number and alleged defect. Seller will then give written instructions to Buyer regarding the manner in which the defective item is to be repaired or replaced. Buyer may be requested to return the item at Buyer's expense, but no return should be made until Buyer has received written instructions from Seller. Seller will then perform under this limited warranty within thirty (30) days after the defective item is returned to Seller.

This document contains the entire limited warranty provided by Seller. The Terms and Conditions contained in this limited warranty may not be modified, altered or waived by any action, inaction or representation, whether oral or in writing, except upon the express written authority of a senior management level employee of Seller. Seller does not authorize any person or persons (except a senior management level employee of Seller) to change the terms of this limited warranty. Seller reserves the right to change or improve the design or manufacture of its products without obligation to modify any product previously manufactured.



Beyond Compressed Gas... Quality Products for Diverse Markets

Sherwood's years of experience in the diverse product lines of compressed gas, propane, specialty gas and life support provide us with the technical expertise to meet your varied needs. Sherwood is your partner for the best quality valves, delivered on time, at the best possible price!



